



Freelance 800F  
Product Catalog  
Version 9.1 – April 2009

**IndustrialIT™**  
▶▶▶enabled

Power and productivity  
for a better world™ **ABB**



# Table of contents

Chapter 1 Introduction .....	7
Chapter 2 System architecture .....	9
2.1 The DigiVis operator level.....	9
2.2 The process level .....	10
2.3 System communication.....	10
2.3.1 Control network .....	10
2.3.2 Station bus (CAN bus) .....	10
2.3.3 OPC .....	11
2.3.4 DMS-API.....	11
2.3.5 Technical details of the control network.....	11
Chapter 3 Automation Sentinel Program .....	13
Chapter 4 The controllers .....	15
4.1 Functions .....	16
4.2 The controller AC 700F.....	18
4.2.1 Central processing unit PM 783F.....	21
4.2.2 CPU terminal base TB 711F .....	23
4.2.3 Accessories for CPU module .....	24
4.3 S700 local I/O .....	25
4.3.1 Digital input / output module DC 732F .....	25
4.3.2 Analog input module AI 723F.....	29
4.3.3 Analog input / output module AX 722F .....	33
4.3.4 I/O terminal unit TU 715F .....	37
4.3.5 Accessoires for I/O modules .....	37
4.3.6 Power supplies.....	38
4.3.7 Accessoires for power supplies .....	40
4.4 The controller AC 800F.....	41
4.4.1 AC 800F, pre-assembled stations.....	49
4.4.2 AC 800F, base units PM 802F / PM 803F .....	50
4.4.3 Power supply SA 811F.....	52
4.4.4 Power supply SD 812F.....	54
4.4.5 Ethernet interface EI 811F, 10Base2 .....	56
4.4.6 Ethernet interface EI 812F, AUI.....	58
4.4.7 Ethernet interface EI 813F, 10BaseT .....	60
4.4.8 CAN-3 module FI 810F .....	62
4.4.9 Serial module FI 820F .....	64
4.4.10 Profibus module FI 830F .....	66
4.4.11 FF / HSE module FI 840F.....	68
4.4.12 AC 800F auxiliary module .....	70
4.5 AC 800F accessories .....	72
4.5.1 Battery holder .....	72
4.5.2 Front panel .....	72
4.5.3 Supply cables .....	72
4.5.4 Protection .....	72
4.5.5 CAN cable and serial cable .....	73
4.5.6 Miscellaneous.....	73
4.6 G3 compliant controllers .....	74

# Table of contents - continued

4.6.1	Pre-assembled G3 compliant stations	74
4.6.2	AC 800F-Z base units	75
4.6.3	AC 800F-Z power supplies	75
4.6.4	AC 800F-Z ethernet interface modules	76
4.6.5	AC 800F-Z fieldbus interface modules	76
4.6.6	AC 800F-Z auxiliary modules	77
4.7	Common accessories for AC 800F / 800F-Z	78
4.7.1	Clips and clamps	78
4.7.2	Battery	78
4.7.3	Protection	79
4.7.4	Cables	79
4.7.5	Auxiliary power supply	79
<b>Chapter 5 Remote I/Os</b>		<b>81</b>
5.1	S800 Remote I/O	82
5.1.1	Communication	82
5.1.1.1	Field communication interfaces	82
5.1.1.2	Upgrade kit and tool cables	84
5.1.2	S800 I/O modules	85
5.1.2.1	Analog input modules	85
5.1.2.2	Analog output modules	87
5.1.2.3	Digital input modules	88
5.1.2.4	Digital output modules	89
5.1.2.5	Pulse counting modules	90
5.1.2.6	Label sets for I/O modules	90
5.1.2.7	Module termination units	91
5.1.3	S800L modules	93
5.1.3.1	Analog input modules	93
5.1.3.2	Analog output modules	93
5.1.3.3	Digital input modules	93
5.1.3.4	Digital output modules	93
5.1.3.5	Label sets for S800L I/O modules	94
5.1.4	ModuleBus communication parts	95
5.1.5	Power supplies	97
5.1.6	User documentation	98
5.2	S900 Remote I/O	99
5.2.1	Redundant termination unit TU921S/B/N	105
5.2.2	Power supply SA920S/B/N	106
5.2.3	Communication interface CI920S/B/N	108
5.2.4	Digital I/O modules DX910S/B/N	109
5.2.5	Solenoid driver DO910S/B/N	110
5.2.6	Relay output DO930N	111
5.2.7	Frequency input DP910S/B/N	112
5.2.8	Analog input AI910S/B/N	113
5.2.9	Analog input, HART, AI930S/B/N	114
5.2.10	Analog input, HART, pass., AI931S/B/N	115
5.2.11	Temperature input AI950S/B/N	116
5.2.12	Analog output AO910S/B/N	117

# Table of contents - continued

5.2.13	Analog output, isolated AO920S/B/N .....	118
5.2.14	Analog output, HART, AO930S/B/N .....	119
5.2.15	Field housing FH660S, FH680S .....	120
5.2.16	Field Housing roof .....	122
5.2.17	Compact box CB220S/B/N .....	123
5.2.18	Power supply SA911S/B/N for CB220x .....	125
5.2.19	Accessories for S900 Remote I/O .....	126
5.2.19.1	Fieldbus isolating repeater .....	126
5.2.19.2	Ring-coupler .....	126
5.2.20	Additional accessories .....	127
5.2.21	Software .....	127
<b>Chapter 6</b>	<b>Network components .....</b>	<b>129</b>
6.1	PROFIBUS network components .....	129
6.2	FOUNDATION Fieldbus network components .....	130
<b>Chapter 7</b>	<b>The Operator Level with DigiVis .....</b>	<b>131</b>
7.1	Messages & operator hints .....	135
7.2	Software subscription .....	137
7.3	DigiVis languages .....	137
7.4	DigiVis license V9.1 .....	137
7.5	DigiVis options .....	138
7.6	DigiVis hardkeys .....	139
<b>Chapter 8</b>	<b>Configuration and commissioning with Control Builder F .....</b>	<b>141</b>
8.1	Configuration of functions .....	143
8.2	Hardware structure .....	146
8.3	Commissioning .....	147
8.4	Control Builder F languages .....	149
8.5	Control Builder F license .....	149
8.6	Control Builder F options .....	150
8.7	Control Builder F hardkeys .....	150
8.8	Control - Software license .....	151
8.8.1	Basic controller .....	151
8.8.2	Additional basic I/Os .....	151
8.8.3	Advanced controller .....	152
8.8.4	Additional advanced I/Os .....	152
8.8.5	Control software options, basic .....	152
8.8.6	Control software options, basic / advanced .....	153
8.8.7	Additional packages .....	153
<b>Chapter 9</b>	<b>Media and documentation .....</b>	<b>155</b>
9.1	Product box .....	155
9.2	Software CD .....	155
9.3	Documentation CD .....	155
<b>Chapter 10</b>	<b>Add-ons, extensions, and service .....</b>	<b>157</b>



# Chapter 1 Introduction

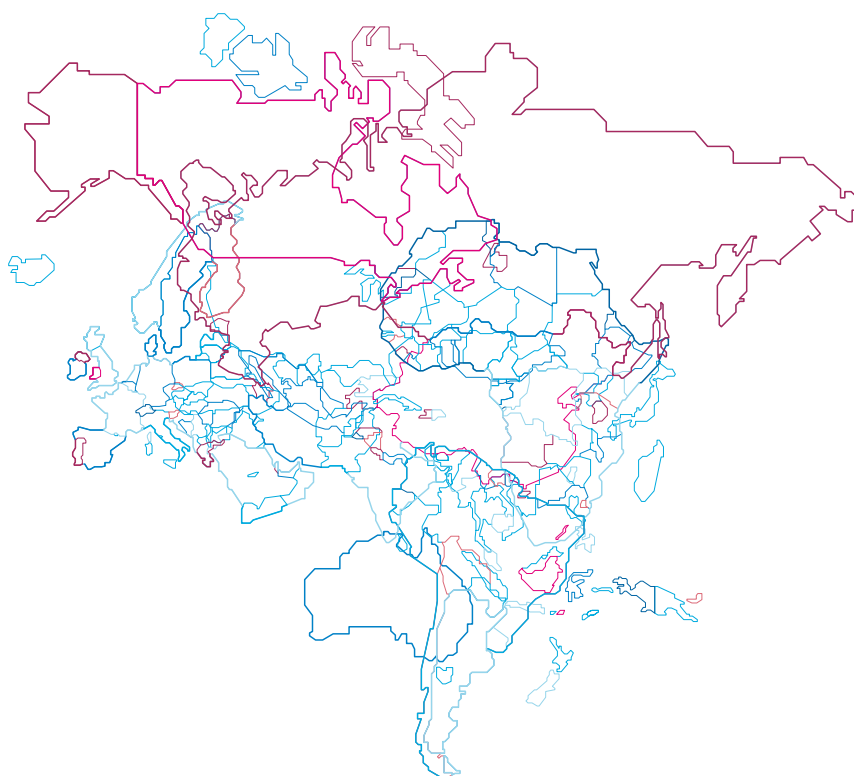

The objective of process industry companies today is clearly defined: increased automation at lower cost. Based on this principle, ABB has redefined compact, scalable control systems, and is today viewed by many as a trend-setter in this industry.

Today, people are impressed by the global success story of Freelance 800F, with more than ten thousand applications covering all industry sectors. With the compact control system Freelance 800F, ABB has taken a further step forward. Freelance 800F provides powerful automation that is not only cost-effective in terms of hardware and software, but is also very easy to use.

The advanced design of Freelance 800F therefore makes the system ideal for numerous applications in power, process or environmental technology plants.

We call this a compact control system. Freelance 800F is our scalable solution covering the full range from very small to medium size applications, that is, from a few to 1000 I/Os and more.

Ease of use was the requirement we have put on the developers of Freelance 800F from the early beginning. This basic principle constitutes the difference to the PLC arena, where the total engineering effort has to be accomplished with a variety of tools, low level of integration, and a lot of manual work.

Cost cutting is the essential benchmark for engineering tools. With Freelance 800F this scenario is filled with several items:

- Use of only one engineering tool (Control Builder F) to configure the entire system, consisting of automation functions, graphics, the operator interface, fieldbus lines (Profibus®, FOUNDATION™ Fieldbus, HART®, etc.), parameters and field devices
- Automatic generation of the entire communication between controllers and operator stations
- System-wide single source data treatment for controllers, operator stations, and field devices, leading to data consistency within the entire system
- Uniform, system-wide plausibility check of user programs covering all process and operator stations up to intelligent field devices. The plausibility check includes the formal check for completeness and consistency of the user programs
- Graphical configuration with high-performance editors in programming languages according to IEC 61131-3
  - Function block diagram (FBD)
  - Ladder diagram (LD)
  - Instruction list (IL)
  - Sequential function chart (SFC)
  - Structured text (ST)
- Extensive function block library, to which user defined function blocks can be added; macro libraries and graphic symbols to create graphics and faceplates for user defined function blocks

- Integration of any PROFIBUS-DP and PA slave using the concept of the generic slave (via a GSD-file) with the possibility of configuring these components in user-defined dialogs
- Integration of PROFIBUS devices using FDT technology

The same user-friendly configuration and support features also apply to the operation level. The operator is supported by a mechanism providing not only information from the plant but also operating hints, which can serve as simplified SOP (Standard Operating Procedures). For this purpose, for example, an intuitive operator interface, logs, and sophisticated alarm and message management function are available.

The quality of Freelance 800F is also reflected in the robust hardware, which is immune to electromagnetic interference and bears the CE, UL and GL Mark as a quality symbol for all its components.

In cases where demands on availability are particularly high, it is possible to configure the controller including the modules redundantly. Fieldbus lines and the operator stations can also be configured redundantly. The availability of the control network can be increased by using ring topologies. Redundant configuration is done without any additional engineering effort.

The Freelance 800F control system provides powerful automation that is cost-effective and easy to use. Freelance 800F is ideally suited to applications requiring simple handling and attractively-priced hardware and software in power, process or environmental industry.

It is a sound investment in the future, with a straightforward and clearly designed system based on the motto:

Minimum engineering – maximum automation



# Chapter 2 System architecture

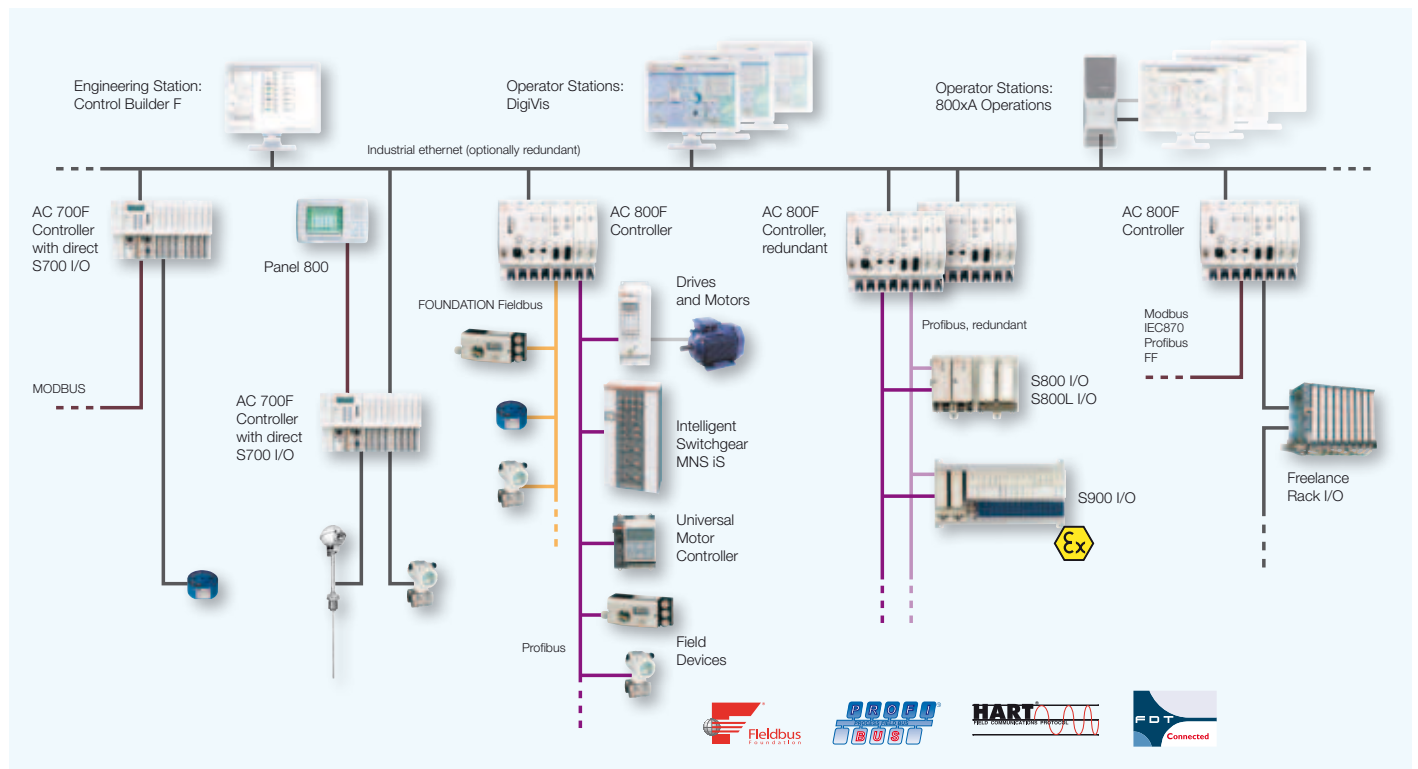

Freelance 800F provides an operator level and a process level. The operator level contains the functions for operation and observation, archives and logs, trends and alarms. Open-loop and closed-loop control functions are processed in the controllers which communicate with actors and sensors in the field.

At the left side of the figure above you see the new AC 700F controller with field devices connected to its local I/O. Thanks to the flexibility of Ethernet and its small footprint, AC 700F can also be placed in local mounting boxes in non-hazardous areas out in the field as competitive, intelligent Ethernet I/O.

In the center you see a standard AC 800F controller and next to it - for highest availability - redundant AC 800F controllers. Connected to these controllers you'll find Profibus and FOUNDATION Fieldbus devices. The entire fieldbus management is done with one engineering tool, Control Builder F.

Connected to the redundant controllers you see ABB's Profibus remote I/Os, S800 for standard<sup>1</sup> and S900 for hazardous areas. Connected to the rightmost AC 800F controller, there are traditional 19 inch rack-I/Os which are still available and supported.

## 2.1 The DigiVis operator level

The DigiVis operator stations use PC hardware, either standard or industrialized in line with the application, running under the Microsoft® Windows® operating system. DigiVis supports dual-monitor operation, which offers the benefit to stay continuously tuned with essential information like the alarm list, while inspecting at the same time the progress of a sequential function chart.

The Control Builder F engineering station is used to configure and commission the system. Usually, portable equipment such as laptops, which allow configuration both in the office and on site, is used. The operator level PCs can also be used as engineering station. A permanent connection to the engineering system is not necessary.

1 Signals can be from Zone 1 or 2

## 2.2 The process level

A Freelance 800F system can consist of between one and several AC 700F controllers and / or AC 800F controllers and can be extended with different types of I/O units.

With AC 800F you have the option of configuring your system either standard or fully redundant.

AC 700F is meant for small applications with up to 256 I/O signals per AC 700F controller. This PLC-like controller comes with a very small footprint. S700 local I/O modules can be directly plugged to the controller module. The connection to the Freelance 800F control network is achieved via Ethernet as for all other controllers. This allows among other advantages to place AC 700F directly in the field where needed, offering a very flexible and cost-effective solution when intelligent I/O modules are needed.

AC 800F can be equipped with a set of fieldbus modules, covering all major fieldbuses used in process automation. With AC 800F you have the option to run these controllers either redundantly (CPU redundancy, fieldbus module redundancy) or without redundancy. Modular plug-in input/output modules are used in accordance with the type and quantity of process signals. With AC 800F, fieldbus-compliant components such as remote I/O, field devices, and network components can be used. ABB offers equipment for applications covering standard and hazardous areas. Furthermore G3 compliant AC 800F modules are available.

## 2.3 System communication

The operator and process levels communicate with each other via the control network, based on Ethernet, with TCP/IP, where you can choose between various transmission media such as twisted pair or fiber optic cable. The Freelance 800F OPC server is available for connecting to higher-level operator stations (System 800xA) or other OPC clients. The real-time process values and alarms from the Freelance 800F system can be accessed via OPC. A „C“ programming interface for Windows programs can be used for external applications that do not use the standard OPC interface.

### 2.3.1 Control network

The control network connects the controllers, operator stations and engineering station in the Freelance 800F system.

The control network complies with the Ethernet Standard according to DIN/ISO 8802, Part 3 (IEEE 802.3) and can be used with twisted pair, fiber optic or coaxial cable. It is also possible to use a combination of these standards or to implement 1-Gbit/s components within a network as high-speed backbone.

Freelance 800F uses confirmed and unconfirmed services. The unconfirmed UDP service is used for screen updating and lateral communication between controllers. The confirmed TCP/IP service is used for alarming and trend archiving.

The control network has the following features:

- The ability to cover long distances
- A high data throughput
- A flexible network layout

### 2.3.2 Station bus (CAN bus)

When Freelance 800F I/O racks are used, which can be locally connected to AC 800F, communication takes place via the station bus. The station bus complies with the CAN (Controller Area Network) industrial standard.

The station bus has the following features:

- The ability to cover short to medium distances
- High data throughput, update times for signals from 2 ms (binary) or 10 ms (analog)
- Exceptional degree of transmission safety and interference immunity (Hamming distance = 6)
- Pre-programmed routines in the event of faults
- Good EMC properties
- Ability to switch bus members on and off during operation
- Automatic initialization of newly mounted modules

## 2.3.3 OPC

Freelance 800F provides an OPC gateway (server), which allows OPC clients to access data and alarms from the Freelance 800F controllers. From Freelance 800F version 7.1 upwards, the OPC server also allows access to the DPV1 parameters and user parameters of PROFIBUS and HART devices. In the case of HART devices, this is only possible if they are connected to an S900 remote I/O unit. For Freelance 800F version 8.2 and higher, the parameters of FOUNDATION Fieldbus devices can also be accessed.

It is possible to limit access to this data at the OPC gateway such that an OPC client cannot see certain tags and variables at all, can only read other tags and variables, or has both read and write access to certain tags and variables.

The DigiVis operator station has a built-in OPC client, which permits you to access data from external OPC servers. Using this, for example, data from other controllers or even SIE-MENS control units can be integrated into a custom graphic in DigiVis.

As several OPC gateways can be used in the Freelance 800F system, server redundancy can be established using OPC clients that support this function.<sup>2</sup> The Control Builder F engineering software supports this with the redundant OPC gateway configuration.

The trend server option provides a special OPC gateway that is used by the DigiVis operator stations for user-defined trend displays. Access to the trend server is fixed to “read only”, and all trend variables are automatically available. There is one trend server per Freelance 800F system.

## 2.3.4 DMS-API

The DMS Application Programming Interface provides C programmers with a Windows interface through which they can access internal Freelance 800F communications services. This enables them to create their own Windows applications that can read online data from the Freelance 800F system and create values

## 2.3.5 Technical details of the control network

Details of the control network		
Bus type:	Twisted Pair (TP)	Fiber optic (FL)
Max. length:	5 x 100 m 5 x 400 m for shielded TP	4500 m
Application:	Control network connection of Freelance 800F operator stations (for operation and observation), engineering station and controllers	
Standard:	DIN/ISO 8802 Part 3 (IEEE 802.3) 10BASE-FL	DIN/ISO 8802 Part 3 10BASE-FL (IEEE 802.3)
Transmission rate:	10/100 MBit/s	10/100 MBit/s

<sup>2</sup> 800xA Operations and Process Portal B supports server redundancy



# Chapter 3 Automation Sentinel Program



Control system lifecycle management and investment protection have always been cornerstones of ABB's development programs. Its mission of "Evolution through Enhancement" has set the industry Gold Standard for lifecycle support for control systems.

Freelance has a good tradition of maintaining your installed investment. The latest software still runs on the the very first generation of controllers as well as the configuration of the first generation can still be used in the latest version of Freelance controllers and software versions.

Automation Sentinel is a software asset management program that extends support for and the value of existing ABB control system software investments.

The Automation Sentinel Program assists system owners in actively managing their lifecycle costs in ABB control system software. With this program, they can keep control software up-to-date and maintain a flexible path forward to new system software technology. Automation Sentinel helps manage automation software assets with timely delivery of the latest system software releases, thus providing subscribers:

- Better productivity through enhanced software functionality
- Lower support cost and simpler software management through known annual subscription fee
- A way to stay current with the latest Industry/IT standards
- Access to the most current system documentation
- Evolution to higher level of human system interface, control, information management, and connectivity
- Evolution from traditional control systems to Freelance 800F to profit from the ease-of-use and lower maintenance cost

Focused on maximizing Return on Assets (ROA) through Operational Excellence (OpX), plant managers look to improve overall productivity from their installed system by (1) adding new functions and features (improving performance), (2) extending its useful life and the applications within it (improving availability), and (3) reducing maintenance costs while improving overall reliability (improving quality).

With business conditions constantly changing, requiring faster turnarounds, greater customization, smaller lot sizes, and lower overall costs, more is required than what the first generation DCS systems could offer.

Today's collaborative process automation systems synchronize all process operations within one common environment for operations, engineering, and information.

These system qualities allow plant operations to improve:

- Plant effectiveness – combining the right decisions with optimized work processes
- Plant agility – making 'on-the-fly' adjustments as business opportunities present themselves
- Performance – providing all plant personnel with the real-time performance and feedback

In response to system owner needs, the Automation Sentinel program provides the means to keep installed systems performing at a high level to meet production needs. It also provides the evolution path to newer technology system enhancements to improve plant effectiveness and long-term system software support through annual maintenance subscription budgeting. Automation Sentinel provides the most cost effective path to stay up-to date with Freelance 800F.

## Lifecycle management

Automation Sentinel supports lifecycle management of control system software assets.

For many system owners, the expected useful life of their control systems is in the range of 20 to 25 years. However, control system technologies have changed substantially over the past 10 to 15 years. Systems now contain a substantial amount of Commercial-Off-the-Shelf (COTS) information technology in both the platform and software dimensions. As a result, system lifecycle costs are becoming much more difficult to predict and control.

To allow companies to control these costs, ABB has a formal written policy that governs its products' lifecycle. This policy is the most comprehensive and progressive control system lifecycle approach and guides ABB's behavior in the development, delivery and support of its control system products.

Through the policy, the uncertainty and unpredictability of lifecycle management costs have been removed, which in turn allows system owners to make informed decisions, confidently plan budgets, and over the long-term, effectively control their lifecycle costs.

Automation Sentinel Program is the delivery mechanism for this software lifecycle policy. It provides clearly defined software support for installed products throughout the lifecycle phases. The program supports the system owner's lifecycle plans and needs through annual subscriptions providing for lowest system management cost with a predictable annual fee.

Unlike other software management programs, Automation Sentinel subscription is based on the installed system and does not require the management of individual software products.

Automation Sentinel is a general lifecycle management program which is interesting for both, system integrators and endcustomers.

If you need more information contact your local sales person or visit the Freelance 800F section of [www.abb.com/controlsystems](http://www.abb.com/controlsystems).

# Chapter 4 The controllers



The process level is the domain of controllers. Their functions and modularity define - together with the engineering tool - the ease of use, scalability, and performance of a DCS system. Freelance 800F comes with two different types of controllers, the new AC 700F controller and the AC 800F controller being well introduced since years and running in many, many applications.

A Freelance 800F system can consist of between one and several AC 700F controllers and / or AC 800F controllers and can be extended with different types of I/O units. With AC 800F you have the option of configuring your system either standard or fully redundant.

AC 700F, which comes along with a very small footprint, is particularly suitable for small applications consisting of very few to several hundreds I/O signals. Up to eight local S700 I/O modules can be plugged to the controller. Thanks to the flexibility of Ethernet and its small footprint, AC 700F can also be placed in local mounting boxes in non-hazardous areas out in the field as competitive, intelligent Ethernet I/O.

AC 800F encompasses the wide area from small to medium sized application covering the almost entire spectrum of applications.

A single controller is able to feed several fieldbus lines running the main fieldbuses of process industries, Modbus, Profibus and FOUNDATION Fieldbus. And for sure, if HART devices are connected to remote I/Os, their HART variables are available throughout the system.

Both controller types can be used side by side within a project and can easily communicate with each other via the Ethernet based control network. Engineering is performed with one engineering tool, Control Builder F. All function blocks and pre-engineered functions are available for both controllers in the same way.



## 4.1 Functions

The scope of functions provided by the Freelance 800F system corresponds to the basic supply defined in IEC 61131-3, in addition to numerous other high performance, industry-proven functions and function blocks. Furthermore user-specific function blocks can be added for dedicated tasks. During configuration, the processing capacity and speed of the controllers can be easily adapted to the demands of the automation task. Program execution in the controller is based on real-time multitasking operating system, leading to flexible strategies for processing programs.

The operating system of the controllers has two different types of tasks, system tasks and user tasks. System tasks supervise the system for example at cold start or in case of an error. User tasks execute the application programs.

Different modes are available for user task execution:

- Cyclical processing of at maximum eight priority driven tasks with cycle times from 5 ms upwards
- Processing as fast as possible (PLC mode); one task only

System tasks are automatically available. These tasks are executed once in case of the following events:

- RUN
- STOP
- COLD START
- WARM START (voltage restored)
- REDUNDANCY TOGGLE
- ERROR

It is possible to add your own applications to these tasks.

Functions and function blocks	
Analog value processing	Input and output conversion Linearization Delay and dead-time filter Average / extreme value determination in time Setpoint adjustment Counter with analog input Time scheduler
Binary value processing	Binary output, monostable Input and output delay Pulse / Time Counter, pushbutton
Closed-loop control	Continuous controllers (PID) Step controllers On / Off controller, three-position controller Ratio controller Basic functions Auto-tuning
Open-loop control	Individual drive functions Sequence control, dosing circuits
Logic functions	Logic processing Average / Extreme value determination Comparator, binary switch Multiplexer Converter (data type & code) Flip-flop, edge detection String blocks Radio controlled adjustment of daylight-saving time



## Functions and function blocks

Monitoring	Analog and binary monitoring Event monitoring Audible alarm control Connection monitoring Sequence-of-Events (SOE)
Acquisition Arithmetic functions	Disturbance course acquisition, trend acquisition Basic arithmetic functions, numerical functions Logarithmic functions Trigonometric functions Analog value and time limitation
Modbus functions PROFIBUS	Master and slave functions DPV1 master functions for AC 800F
FOUNDATION Fieldbus (FF) Send / Receive	FF High Speed Ethernet (HSE / H1) for AC 800F Send and receive blocks for interdevice communication
Phase logic processing	Interface module for batch applications

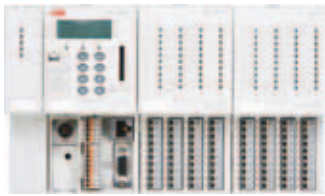

## 4.2 The controller AC 700F

The AC 700F controller is a process station with really small footprint and high signal density of local S700 I/O. The S700 I/O modules are directly plugged to the CPU module. A maximum of eight modules can be connected to one controller. 3rd party I/O's can be connected via a MODBUS ASCII / RTU serial bus.

AC 700F is based on hardware that is successfully used as PLC in practice for years in factory automation. The AC 700F controller, as a member of Freelance 800F, has numerous advantage over a PLC based solution: The compact process control system simplifies engineering, commissioning, and maintenance of the automation system. Visualization is directly incorporated into the engineering, making configuration particularly straightforward. Small or distributed plant components can now be implemented cost effectively by using AC 700F. The competitive advantage is clear: the same engineering, operation and maintenance method for all plant components hand in hand with the well-known ease of use of Freelance 800F.

### The AC 700F hardware

The AC 700F comes with a modular design. The base elements are different types of terminal units, one for the CPU module and one for S700 I/O modules. The modules can be easily plugged to the terminal units and then the terminal units can be plugged one to the other. The entire controller is then mounted on a DIN rail.

The CPU and the local S700 I/O modules communicate very fast. I/O scan times of 2 ms are possible. Short circuit and line break detection is realized for each channel. The temperature range of AC 700F extends from 0 °C to 60 °C / 32-140 °F.

Certification according to CE, UL, and GL enables AC 700F to be used in a wide variety of applications.

### Technical data

The AC 700F controller is designed according to the EN 61131-2 / IEC 61131-2 standards. Data that differ from the IEC 61131 standards are caused due to the high requirements of Maritime Services.

### Climatic stress

Module temperature	Operating:	Temperature range: 0 °C (32 °F) ..+60 °C (140 °F) Highly recommended mounting: horizontally
		⚠ Vertical mounting: Vertical mounting is possible, however, derating considerations should be made to avoid problems with poor air circulation and the potential for excessive temperatures. Temperature range: 0 °C (32 °F) ..+40 °C / 104 °F 50% output load derating
	Storage:	-25 °C (-13 °F)...+75 °C (167 °F)
	Transport:	-25 °C (-13 °F)...+75 °C (167 °F)
Battery temperature	Operating:	0 °C (32 °F)...+60 °C (140 °F)
	Storage:	-20 °C (-4 °F)...+60 °C (140 °F)
	Transport:	-20 °C (-4 °F)...+60 °C (140 °F)
Humidity		Maximum 95%, without condensation
Air pressure	Operating:	> 800 hPa / < 2000 m
	Storage:	> 660 hPa / < 3500 m

## Mechanical stress

Mounting	Horizontal
Degree of protection	IP 20
Housing	According to UL 94
Vibration resistance according to EN 61131-2	All three axes 2 Hz...15 Hz, continuous 3.5 mm (0.1379 inch) 15 Hz...150 Hz, continuous 1 g (0.04 oz) (4 g (0.14 oz) in preparation)
Shock test	All three axes 15 g (0.53 oz), 11 ms, half-sinusoidal
Mounting of the modules	DIN-rail according to DIN EN 50022, 35 mm (1.38 inch), depth 7.5 mm (0.2955 inch) or 15 mm (0.591 inch), mounting with screws of type M4, fastening torque 1.2 Nm

## Electromagnetic compatibility

### Immunity against electrostatic discharge (ESD) as per EN 61000-4-2, Zone B, criterion B

Electrostatic voltage in case of air discharge	8 kV
Electrostatic voltage in case of contact discharge	4 kV, 6 kV in a closed switch gear cabinet
ESD in the communication ports	In order to prevent operating malfunctions, it is recommended that the operating personnel discharge themselves prior to touching communication ports or take other necessary action to reduce the effects of electrostatic discharges.
ESD in CPU Terminal Base ports	The connector to the CPU Terminal Base present on the bottom side of the modules should not be touched when it is charged. The same is true for the lateral connector to the I/O Bus.

### Immunity against influence of radiated disturbances (CW radiated) as per EN 61000-4-3, Zone B, criterion A

Test field strength	10 V / m
---------------------	----------

### Immunity against transient interference voltages (burst) as per EN 61000-4-4, Zone B, criterion B

Supply voltage (AC, DC)	2 kV
Digital inputs / outputs (24 VDC)	1 kV
Digital inputs / outputs (120 / 230 VAC)	2 kV
Analog inputs / outputs	1 kV
Serial RS-485 interface (COM)	2 kV
Serial RS-232 interfaces (COM)	1 kV
Ethernet	1 kV
I/O supply, DC-out	1 kV

### Immunity against the influence of line conducted interferences (CW conducted) as per EN 61000-4-6, Zone B, criterion A

Test voltage	3 V Zone B, 10 V is also met
--------------	------------------------------

<b>High energy surges as per EN 61000-4-5, Zone B, criterion B</b>	
Power supply AC	2 kV CM* / 1 kV DM*
Power supply DC	1 kV CM* / 0,5 kV DM*
DC I/O supply, add. DC-supply-out	0.5 kV CM* / 0.5 kV DM*
Buses, shielded	1 kV CM*
I/O analog, I/O DC unshielded	1 kV CM* / 0,5 kV DM*
<b>Radiation (radio disturbance) as per EN 55011, group 1, class A</b>	
* CM = Common Mode, * DM = Differential Mode	

## Electric data

<b>Voltages according to EN 61131-2</b>	
Process- and Supply-voltage	24 VDC (-15 %, +20 % without ripple)
Absolute limits	19.2 V...30 V incl. Ripple (see below)
Ripple	< 5 %
Protection against reverse polarity	10 s
<b>Permissible interruptions of power supply as per EN 61131-2</b>	
DC supply	Interruption < 10 ms, time between 2 interruptions > 1 s, PS2
<b>Creepage distances and clearances</b>	
The creepage distances and clearances meet the overvoltage category II, pollution degree 2.	
<b>Power supply units</b>	
Power supply units meeting the PELV specification should be used for powering the modules.	

## Insulation test voltages, routine test, as per EN 61131-2

230 V circuits against other circuitry	2500 V	Surge 1.2 / 50 µs
120 V circuits against other circuitry	1500 V	Surge 1.2 / 50 µs
120-240 V circuits against other circuitry	2500 V	Surge 1.2 / 50 µs
24 V circuits (supply, 24 V inputs / outputs), if they are electrically isolated against other circuitry.	500 V	Surge 1.2 / 50 µs
COM interfaces, electrically isolated	500 V	Surge 1.2 / 50 µs
Ethernet	500 V	Surge 1.2 / 50 µs
24 V circuits (supply, 24 inputs / outputs), if they are electrically isolated against other circuitry	350 V	AC 2 s
COM interfaces, electrically isolated	350 V	AC 2 s
Ethernet	350 V	AC 2 s



## 4.2.1 Central processing unit PM 783F

Name	Short Description	Article No.
PM 783F	Central Processing Unit (2 MB)  Needs external 24 VDC power supply. Without terminal base. The operating system has to be loaded by Control Builder F. For AC 700F, Control Builder F of Version 9.1 or later is mandatory.	3BDH000364R0001

The Central Processing Unit (CPU) module is equipped with a high-performance processor for fast loop cycle times. It comes with on-board 100 Mbit/s Ethernet network connection used for communication between controllers, operator stations, and engineering tool. Two serial line interfaces complement the connectivity. One interface is used for Modbus communication, while the other is used for diagnostics. For demanding applications, eight cyclic and priority driven tasks with adjustable cycle time can be configured, as well as a cyclic PLC type task, which runs as fast as possible. This multi-tasking scenario enables engineers to design applications that reflect all demands of process control, while at the same time balancing the CPU load. This keeps the resources needed in a project at the minimum.

The front panel display shows status and diagnostic information directly at the module.

### Technical data

Technical data PM 783F	
CPU	Motorola® PowerPC® (MPC8247)
RAM	Program memory (battery backed up) 2 MB SRAM Internal memory 8 MB SDRAM, 4 MB FLASH ROM
Processing time for 1000 instructions	1.667 ms for binary instructions 2.322 ms for word instructions 3.125 ms for floating point instructions
Max. number of I/O modules	8
Power supply	CP-C 24 / 5.0, power supply, 5 A / 24 VDC output CP-C 24 / 10.0, power supply, 10 A / 24 VDC output
Max. power dissipation within the module	10 W
Current consumption from 24 VDC	80 mA (max)
Inrush current at 24 VDC	1 A <sup>2</sup> s
Data backup source	Lithium battery
Data buffering time at 25 °C / 77 °F	Approximately 1.5 years
Battery low indication	Warning indication issued about 2 weeks before the battery charge becomes critical
Real-time clock, with battery backup	Yes
Multitasking program execution	
Cyclic (equidistant)	8 tasks
Cyclic (as fast as possible)	1 PLC type task
Event driven	Upon any of these events: “Run, Stop, Warm start, Cold start, Error“

#### Technical data PM 783F

Serial interface "SER" (COM1) (see [Figure 1](#) of the Terminal Base TB 711F)

Physical link:	Configurable for RS-232 or RS-485 (from 1200 bps to 38400 bps)
Connection:	Pluggable terminal block, spring connection
Usage:	Modbus - ASCII (Master / Slave) - RTU (Master / Slave)

Serial interface "DIAG" (COM2) (see [Figure 1](#) of the Terminal Base TB 711F)

Physical link:	RS-232
Connection:	SUB-D female connector
Usage:	For diagnostics

Onboard network interface	1 x Ethernet (RJ45) 100 Mbit/s
---------------------------	--------------------------------

LEDs, LCD display, 8 function keys	For RUN / STOP switch-over, status displays and diagnostics
------------------------------------	---

Weight (CPU without the Terminal Base)	150 g / 5.29 oz.
--	------------------

Dimensions (CPU without the Terminal Base)	Width 67.5 mm, 2.66 inches Height 76 mm, 2.99 inches Depth 54 mm, 2.13 inches
--	---

Certifications	CE, GL, UL
----------------	------------

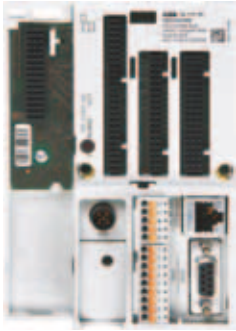

## 4.2.2 CPU terminal base TB 711F

Name	Short Description	Article No.
TB 711F	CPU Terminal Base 24 VDC, 1x Coupler slots, Ethernet RJ45.	3BDH000365R0001

### Technical data

Technical data TB 711F	
Connection of the 24 VDC process voltage	With a 5-pole removable terminal block
Slots	1 CPU, 1 Communication module (not used currently)
Interfaces	Field I/O: 1 for I/O-Bus Serial ports: 2 ("SER" (COM1), "DIAG" (COM2)) Networking: 1 Ethernet (RJ45)
Weight	175 g / 6.17 oz.
Dimensions (with CPU inserted)	Width 95.5 mm, 3.75 inches Height 135 mm, 5.31 inches Depth 75 mm, 2.95 inches

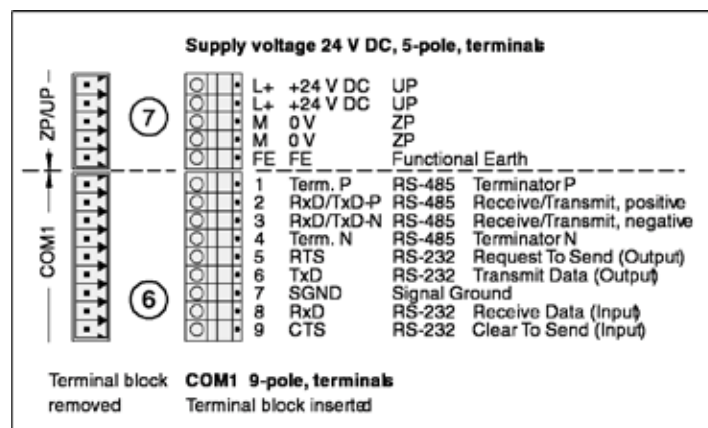
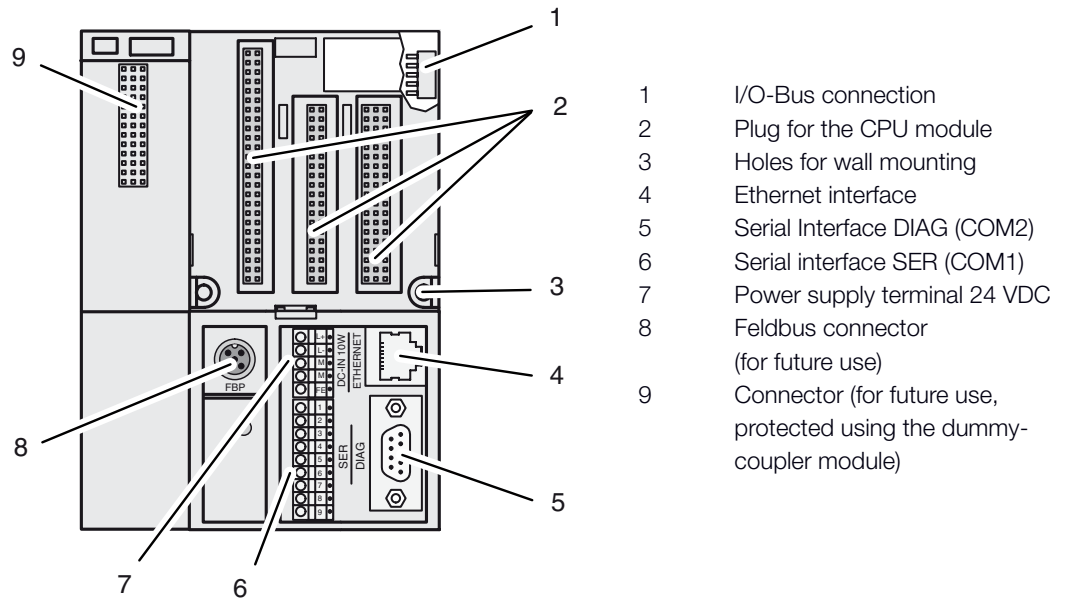
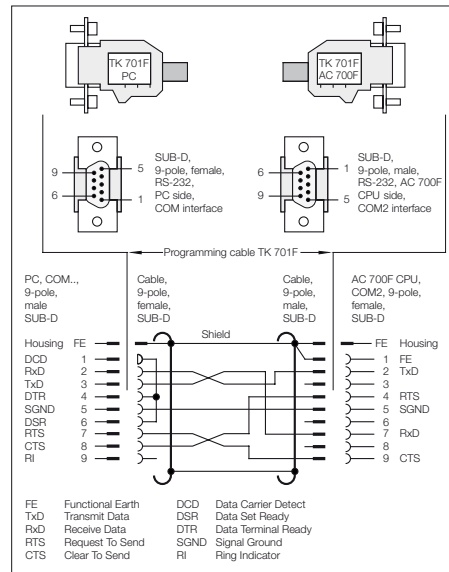

Figure 1: Terminal assignment for supply voltage (24 VDC) and the serial interface SER (COM1)

## 4.2.3 Accessories for CPU module

Name	Short Description	Article No.
TK 701F	Diagnostic Serial Cable, Sub-D / Sub-D, 5 m / 16.4 ft.	3BDH000366R0001



Name	Short Description	Article No.
TA 521	Battery for RAM buffering	1SAP180300R0001



Name	Short Description	Article No.
TA 724F	Dummy Coupler Module	3BDH000367R0001

Empty module, to protect the unused coupler slot from dust and touch.  
Is mounted on the CPU Terminal Base TB 711F.

Name	Short Description	Article No.
TA526	Accessories for back-plate mounting, 10 pcs. With wall mounting of Terminal Bases and Terminal Units.	1SAP180800R0001

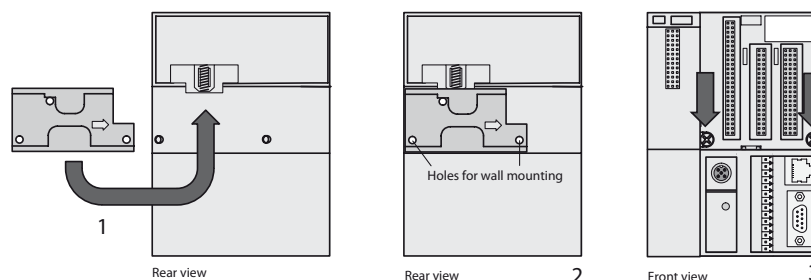
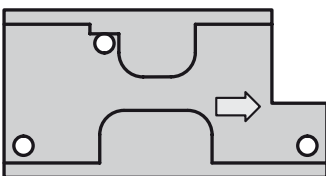



## 4.3 S700 local I/O



### 4.3.1 Digital input / output module DC 732F

Name	Short Description	Article No.
DC 732F	Digital Input / Output Module 16 DI, 16 DC, 24 VDC / 0.5 A, 1-Wire, 24 VDC 200 W. Without terminal unit.	3BDH000375R0001

The DC 732F module handles all digital information in a configurable manner, digital inputs as well as digital outputs. It offers 32 channels. 16 channels are assigned as digital inputs, while the remaining 16 channels can be configured as input or as output.

### Technical data

Functionality DC 732F	
Digital inputs	16 (24 VDC)
Digital inputs / outputs (configurable)	16 (24 VDC)
High-speed counter	Not available
LED displays	For signal statuses, errors and supply voltage
External power supply	Via the terminals ZP and UP (process voltage 24 VDC) of the modules terminal unit TU 715F

Technical data DC 732F	
Process supply voltage UP	
Connections	Terminals 1.8 - 4.8 for +24 V (UP) and 1.9 - 4.9 for 0 V (ZP)
Rated value	24 VDC
Max. ripple	5%
Protection against reversed voltage	Yes
Rated protection fuse on UP	10 A fast
Electrical isolation	Yes, per module
Current consumption	
Internal (via I/O-Bus)	ca. 5 mA at 3.3 VDC
Current consumption from UP at normal operation / with outputs	0.05 A + max. 0.008 A per input + max. 0.5 A per output
Inrush current from UP (at power up)	0.007 A <sup>2</sup> s
Max. power dissipation within the module	6 W (outputs unloaded)
Width x height x depth (without the Terminal Unit)	67.5 x 76 x 54 mm / 2.66 x 2.99 x 2.13 inches
Weight (without Terminal Unit)	Approx. 125 g / 4.41 Oz.
Cooling	The natural convection cooling must not be hindered by cable ducts or other parts in the mounting cabinet.

Technical data of the digital inputs DC 732F	
Number of channels per module	16
Distribution of the channels into groups	1 group of 16 channels
Terminals of the channels I0 to I7	1.0 to 1.7
Terminals of the channels I8 to I15	2.0 to 2.7
Reference potential for all inputs	Terminals 1.9...4.9 (minus pole of the process supply voltage, signal name ZP)
Electrical isolation	From the rest of the module (I/O-Bus)
Indication of the input signals	One yellow LED per channel, the LED is ON when the input signal is high (signal 1)
Input type acc. to EN 61131-2	Type 1
Input delay (0->1 or 1->0)	Typ. 8 ms, configurable from 0.1 to 32 ms
Input signal voltage	24 VDC
Signal 0	-3 V...+5 V
Undefined signal	> +5 V...< +15 V
Signal 1	+15 V...+30 V
Ripple with signal 0	Within -3 V...+5 V
Ripple with signal 1	Within +15 V...+30 V
Input current per channel	
Input voltage +24 V	Typ. 5 mA
Input voltage +5 V	> 1 mA
Input voltage +15 V	> 5 mA
Input voltage +30 V	< 8 mA
Max. cable length	
Shielded	1000 m / 3280 ft.
Unshielded	600 m / 1968 ft.

#### Technical data of the configurable digital inputs / outputs DC 732F

Each of the configurable I/O channels can be wired as input or output by the user.

Number of channels per module	16 inputs / outputs (with transistors)
Distribution of the channels into groups	1 group of 16 channels
If the channels are used as inputs	
Channels I16...I23	Terminals 3.0...3.7
Channels I24...I31	Terminals 4.0...4.7
If the channels are used as outputs	
Channels O16...O23	Terminals 3.0...3.7
Channels O24...O31	Terminals 4.0...4.7
Indication of the input / output signals	One yellow LED per channel, the LED is ON when the input / output signal is high (signal 1)
Electrical isolation	From the rest of the module

#### Technical data of the digital inputs / outputs if used as outputs DC 732F

Number of channels per module	Max. 16 transistor outputs
Reference potential for all outputs	Terminals 1.9...4.9 (minus pole of the process supply voltage, signal name ZP)
Common power supply voltage	For all outputs: terminals 1.8...4.8 (plus pole of the process supply voltage, signal name UP)

#### Technical data of the digital inputs / outputs if used as outputs DC 732F

Output voltage for signal 1	UP -0.8 V
Output delay (0->1 or 1->0)	On request
Output current	
Rated value, per channel	500 mA at UP = 24 V
Maximum value (all channels together)	8 A
Leakage current with signal 0	< 0.5 mA
Rated protection fuse on UP	10 A fast
De-magnetization when inductive loads are switched off	With varistors integrated in the module
Switching frequency	
With resistive load	On request
With inductive loads	Max. 0.5 Hz
With lamp loads	Max. 11 Hz with max. 5 W
Short-circuit proof / overload proof	Yes
Overload message ( $I > 0.7 \text{ A}$ )	Yes, after ca. 100 ms
Output current limitation	Yes, automatic reactivation after short-circuit / overload
Resistance to feedback against 24 V signals	Yes
Max. cable length	
Shielded	1000 m / 3280 ft.
Unshielded	600 m / 1968 ft.

#### Technical data of the digital inputs / outputs if used as inputs DC 732F

Number of channels per module	Max. 16 digital inputs
Reference potential for all inputs	Terminals 1.9...4.9 (minus pole of the process supply voltage, signal name ZP)
Input current, per channel	See „Technical Data of digital inputs“
Input type acc. to EN 61131-2	Type 1
Input delay (0->1 or 1->0)	Typ. 8 ms, configurable from 0.1 to 32 ms
Input signal voltage	24 VDC
Signal 0	-3 V...+5 V *
Undefined signal	> +5 V...< +15 V
Signal 1	+15 V...+30 V
Ripple with signal 0	within -3 V...+5 V *
Ripple with signal 1	within +15 V...+30 V
Max. cable length	
Shielded	1000 m / 3280 ft.
Unshielded	600 m / 1968 ft.

\* Due to the direct connection to the output, the demagnetizing varistor is also effective at the input. This is why the difference between UPx and the input signal may not exceed the clamp voltage of the varistor. The varistor limits the voltage to approx. 36 V. Following this, the input voltage must range from - 12 V to + 30 V when UPx = 24 V and from - 6 V to + 30 V when UPx = 30 V.

The configurable channels are defined by the wiring. As you can see from Figure 2, some of the first 16 input channels show the corresponding wiring. For the next 16 configurable channels you see some examples for inputs (channel 16, 23, 24, and 31) and some examples for outputs (channel 19 and 27). Note that the power has to be supplied depending on the planned power consumption as indicated. The I/O bus supplies the power for the modules electronics only.

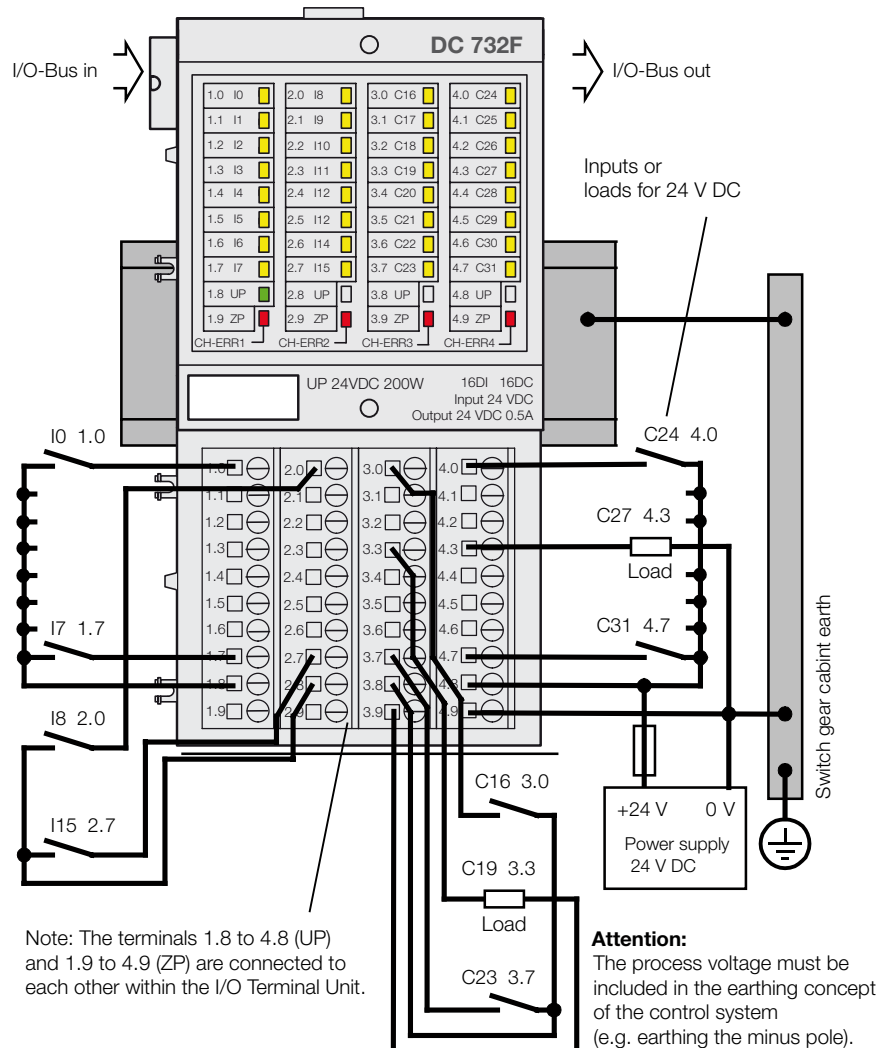

Figure 2: Wiring of DC 732F



## 4.3.2 Analog input module AI 723F

Name	Short Description	Article No.
AI 723F	Analog Input Module  16 AI: $\pm 10$ V, 0/4-20 mA 24 VDC, Pt100 12 bit + Sign, 2-wire, 24 VDC 5 W. Without terminal unit.	3BDH000376R0001

The AI 723F module comes with 16 input channels. Each of these channels can be individually configured depending on its intended usage.

### Possible applications are:

- Sensing a voltage (0...10 V or -10...+10 V)
- Sensing a current (0...20 mA or 4...20 mA)
- Temperature measurement (platinum or nickel resistance thermometers Pt100, Pt1000, Ni1000)
- For 3-wired connections two channels are required

## Technical data

Functionality AI 723F	
16 analog inputs, individually configurable for	Unused (default setting)
	0...10 V
	-10 V...+10 V
	0...20 mA
	4...20 mA
	Pt100, -50 °C (-58 °F)...+400 °C (+752 °F) 2-wire or 3-wire, requires 2 channels
	Pt100, -50 °C (-58 °F)...+70 °C (+158 °F) 2-wire or 3-wire, requires 2 channels
	Pt1000, -50 °C (-58 °F)...+400 °C (+752 °F) 2-wire or 3-wire, requires 2 channels
	Ni1000, -50 °C (-58 °F)...+150 °C (+302 °F) 2-wire or 3-wire, requires 2 channels
	0...10 V with differential inputs, requires 2 channels
	-10 V...+10 V with differential inputs, requires 2 channels
	Digital signals (digital input)

Technical data AI 723F	
LED displays	19 LEDs for signals and error indication
Internal power supply	Through the expansion bus interface (I/O-Bus)
External power supply	Via the terminals ZP and UP (process voltage 24 VDC) of TU 715F
Process voltage	
Rated value	24 VDC
Max. ripple	5%
Protection against reversed voltage	Yes
Rated protection fuse on UP	10 A fast
Electrical isolation	Yes, per module
Current consumption from UP at normal operation	0.15 A
Inrush current from UP (at power up)	0.050 A <sup>2</sup> s
Connections	Terminals 1.8 - 4.8 for +24 V (UP) and 1.9 - 4.9 for 0 V (ZP)
Max. length of analog cables, conductor cross section > 0.14 mm <sup>2</sup> (~26 AWG)	100 m / 328 ft.
Conversion error of the analog values caused by nonlinearity, adjustment error at factory and resolution within the normal range	Typ. 0.5 %, max. 1 %
Width x height x depth (without the Terminal Unit)	67.5 x 76 x 54 mm / 2.66 x 2.99 x 2.13 inches
Weight	300 g / 10.52 oz
Cooling	The natural convection cooling must not be hindered by cable ducts or other parts in the mounting cabinet.

Technical data of the analog inputs AI 723F	
Number of channels per module	16
Distribution of channels into groups	2 groups of 8 channels each
Connections of the channels I0- to I7- Connections of the channels I0+ to I7+	Terminals 1.0 to 1.7 Terminals 2.0 to 2.7
Connections of the channels I8- to I15- Connections of the channels I8+ to I15+	Terminals 3.0 to 3.7 Terminals 4.0 to 4.7
Electrical isolation	Against internal supply and other modules
Configuration	0...10 V, -10...+10 V, 0/4...20 mA, Pt100/1000, Ni1000 (each channel can be configured individually)
Channel input resistance	Voltage: > 100 kOhm, current: ca. 330 Ohm
Time constant of the input filter	Voltage: 100 µs, current: 100 µs
Indication of the input signals	One LED per channel
Resolution	Range 0...10 V: 12 bits Range -10...+10 V: 12 bits + sign Range 0...20 mA: 12 bits Range 4...20 mA: 12 bits Temperature: 0.1 °C / 0.18 °F

### Technical data of the analog inputs AI 723F

Unused voltage inputs	Are configured as „unused“
Unused current inputs	Have a low resistance, can be left open-circuited
Overvoltage protection	Yes

### Technical data of the analog inputs, if they are used as digital inputs AI 723F

Number of channels per module	Max. 16
Distribution of channels into groups	2 groups of 8 channels each
Connections of the channels I0+ to I7+	Terminals 2.0 to 2.7
Connections of the channels I8+ to I15+	Terminals 4.0 to 4.7
Reference potential for the inputs	Terminals 1.8 to 4.8 (ZP)
Input signal delay	Typ. 8 ms
Indication of the input signals	One LED per channel
Input signal voltage	24 VDC
Signal 0	-30 V...+5 V
Signal 1	+13 V...+30 V

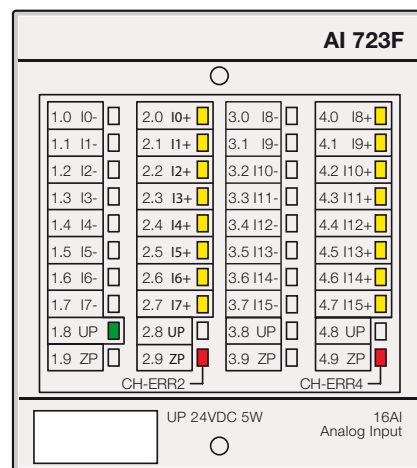

Figure 3: AI 723F

Two example of wiring are shown with the following figures. [Figure 4](#) shows wiring for a current input for 4...20 mA while [Figure 5](#) shows a voltage sensor with differential inputs. Note that the latter one needs two adjacent channels, starting with an even channel number.

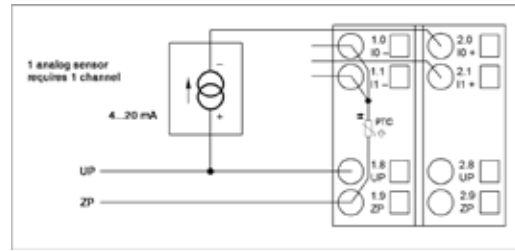

Figure 4: Connection of passive-type analog sensors (current)

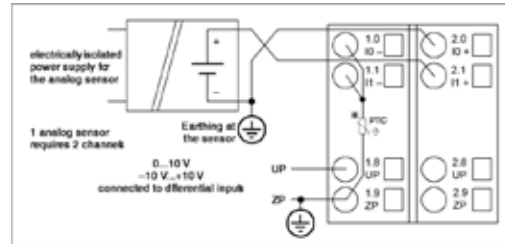

Figure 5: Connection of active-type analog sensors (voltage) to differential inputs

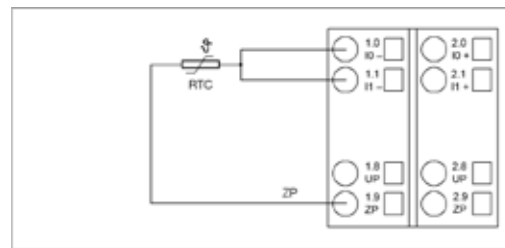

Figure 6: 3 wire RTC





### 4.3.3 Analog input / output module AX 722F

Name	Short Description	Article No.
AX 722F	Analog Input / Output Module	3BDH000377R0001
	8 AI: +-10 V 0/4-20 mA 24 VDC, Pt100. 8 AO: +-10 V 0/4-20 mA 24 VDC. 12 bit + Sign, 2-wire, 24 VDC 5 W. Without terminal unit.	

The AX 722F module offers even more flexibility, as it combines analog input and output channels in one module with 16 channels.

Eight of these channels can be individually configured as inputs, which can again sense voltage, current, or temperatures.

Furthermore four channels can be configured as analog voltage outputs (-10 V to +10 V) or analog current outputs (0 ... 20 mA or 4 ... 20 mA) and the remaining four channels can provide voltage signals in the range from -10 V to +10 V.

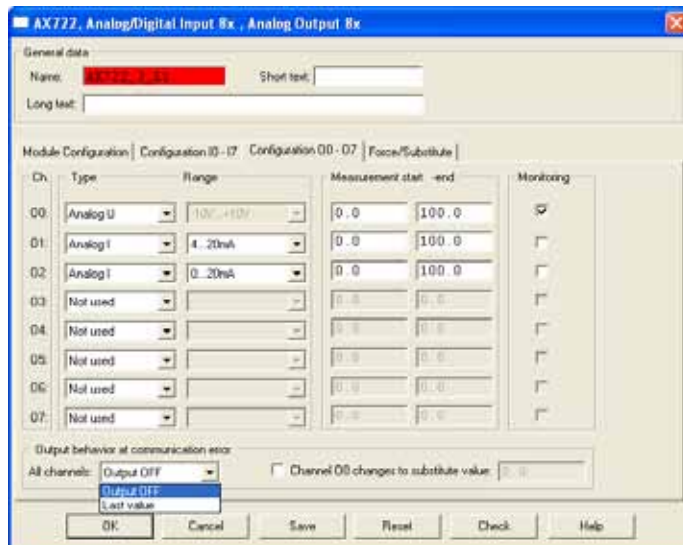
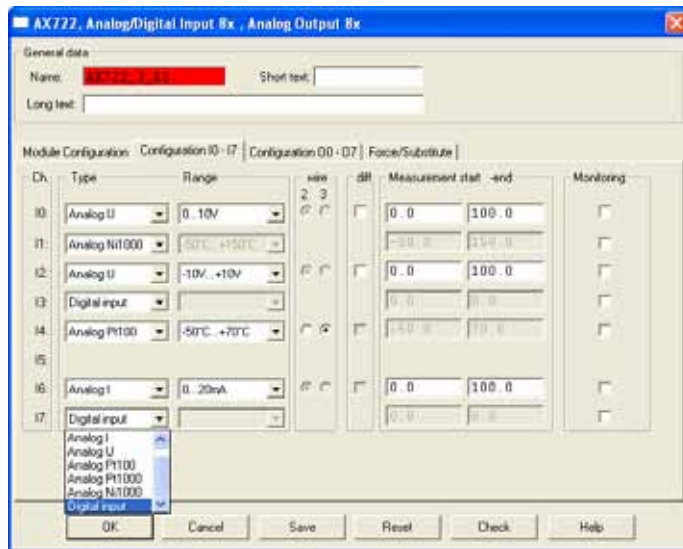

Figure 7: AX 722F options

## Technical data

### Functionality AX 722F

8 analog inputs, (channels I0 - I7) individually configurable for	<p>Unused (default setting)</p> <p>0...10 V</p> <p>-10 V...+10 V</p> <p>0...20 mA</p> <p>4...20 mA</p> <p>Pt100, -50 °C (-58 °F)...+400 °C (+752 °F) 2-wire or 3-wire, requires 2 channels</p> <p>Pt100, -50 °C (-58 °F)...+70 °C (+158 °F) 2-wire or 3-wire, requires 2 channels</p> <p>Pt1000, -50 °C (-58 °F)...+400 °C (+752 °F) 2-wire or 3-wire, requires 2 channels</p> <p>Ni1000, -50 °C (-58 °F)...+150 °C (+302 °F) 2-wire or 3-wire, requires 2 channels</p> <p>0...10 V with differential inputs, requires 2 channels</p> <p>-10 V...+10 V with differential inputs, requires 2 channels</p> <p>Digital signals (digital input)</p>
4 analog outputs, (channels O0 - O3) individually configurable for	<p>Unused (default setting)</p> <p>-10 V...+10 V</p> <p>0...20 mA</p> <p>4...20 mA</p>
4 analog outputs, (channels O4 - O7) individually configurable for	<p>unused (default setting)</p> <p>-10 V...+10 V</p>

### Technical data AX 722F

LED displays	19 LEDs for signals and error indication, where the brightness depends on the current (or signal level)
Internal power supply	Through the expansion bus interface (I/O-Bus)
External power supply	Via the terminals ZP and UP (process voltage 24 VDC) of TU 715F
Process voltage	
Rated value	24 VDC
Max. ripple	5%
Protection against reversed voltage	Yes
Rated protection fuse on UP	10 A fast
Electrical isolation	Yes, per module
Current consumption from UP at normal operation	0.10 A output loads
Inrush current from UP (at power up)	0.020 A <sup>2</sup> s

### Technical data AX 722F

Connections	Terminals 1.8 - 4.8 for +24 V (UP) and 1.9 - 4.9 for 0 V (ZP)
Max. length of analog cables, conductor cross section > 0.14 mm <sup>2</sup> (~26 AWG)	100 m / 328 ft.
Conversion error of the analog values caused by non-linearity, adjustment error at factory and resolution within the normal range	Typ. 0.5 %, max. 1 %
Width x height x depth (without the Terminal Unit)	67.5 x 76 x 54 mm / 2.66 x 2.99 x 2.13 inches
Weight	300 g / 10.58 oz.
Cooling	The natural convection cooling must not be hindered by cable ducts or other parts in the mounting cabinet.

### Technical data of the analog inputs AX 722F

Number of channels per module	8
Distribution of the channels into groups	1 group of 8 channels
Connections of the channels I0- to I7-	Terminals 1.0 to 1.7
Connections of the channels I0+ to I7+	Terminals 2.0 to 2.7
Electrical isolation	Against internal supply and other modules
Configuration	0...10 V, -10...+10 V, 0/4...20 mA, Pt100/1000, Ni1000 (each channel can be configured individually)
Channel input resistance	Voltage: > 100 kOhm, current: ca. 330 Ohm
Time constant of the input filter	Voltage: 100 µs, current: 100 µs
Indication of the input signals	One LED per channel
Conversion cycle	2 ms (for 8 inputs + 8 outputs), with Pt / Ni...1 s
Resolution	Range 0...10 V: 12 bits Range -10...+10 V: 12 bits + sign Range 0...20 mA: 12 bits Range 4...20 mA: 12 bits Temperature : 0.1 °C / 0.18 °F
Unused voltage inputs	Are configured as „unused“
Unused current inputs	Have a low resistance, can be left open-circuited
Overvoltage protection	Yes

Technical data of the analog inputs, if they are used as digital inputs AX 722F	
Number of channels per module	Max. 8
Distribution of channels into groups	1 group of 8 channels
Connections of the channels I0+ to I7+	Terminals 2.0 to 2.7
Reference potential for the inputs	Terminals 1.8 to 4.8 (ZP)
Input signal delay	Typ. 8 ms
Indication of the input signals	One LED per channel
Input signal voltage	24 VDC
Signal 0	-30 V...+5 V
Signal 1	+13 V...+30 V

Technical data of the analog outputs AX 722F	
Number of channels per module	8, all channels for voltage, the first 4 channels also for current
Distribution of channels into groups	1 group of 8 channels
Channels O0-...O7-	Terminals 3.0...3.7
Channels O0+...O7+	Terminals 4.0...4.7
Output type	Bipolar with voltage, unipolar with current
Electrical isolation	Against internal supply and other modules
Configurability	-10...+10 V, 0...20 mA, 4...20 mA (each output can be configured individually), current outputs only channels 0...3
Output resistance (load), as current output	0...500 Ohm
Output loadability, as voltage output	max. ±10 mA
Indication of the output signals	One LED per channel, where the brightness depends on the current (or signal level)
Resolution	12 bits (+ sign)
Unused outputs	Can be left open-circuited

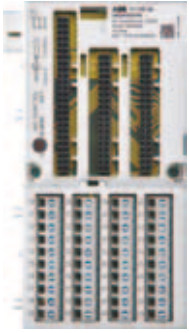

## 4.3.4 I/O terminal unit TU 715F

Name	Short Description	Article No.
TU 715F	I/O Terminal Unit, 24 VDC Screw type terminals, 1/2 wire.	3BDH000378R0001

### Technical data

Technical data TU 715F	
Number of terminals per module	32
Distribution of the channels into groups	4 groups of 8 terminals each (1.0...1.7, 2.0...2.7, 3.0...3.7, 4.0...4.7), the allocation of the channels is given by the inserted I/O expansion module
Rated voltage	24 VDC
Max. permitted total current	10 A (between the terminals 1.8...4.8 and 1.9...4.9)
Earthing	Direct connection to the earthed DIN rail or via the screws with wall mounting
Type	Front terminal, conductor connection vertically with respect to the printed circuit board
Conductor cross section	
Solid	0.08 mm <sup>2</sup> to 2.5 mm <sup>2</sup> (28 AWG to 13 AWG)
Flexible	0.08 mm <sup>2</sup> to 2.5 mm <sup>2</sup> (28 AWG to 13 AWG)
With wire-end ferrule	0.25 mm <sup>2</sup> to 1.5 mm <sup>2</sup> (23 AWG to 15 AWG)
Stripped conductor end	8 mm (0.31 inches)
Width of the screwdriver	3.5 mm (0.14 inches)
Fastening torque (screw type terminals)	0.6 Nm (5.3 Pound Inch)
Degree of protection	IP 20
Weight	200 g / 7.05 oz.
Dimensions	Width 67.5 mm, 2.66 inches Height 135 mm, 5.31 inches Depth 30 mm, 1.18 inches

## 4.3.5 Accessoires for I/O modules

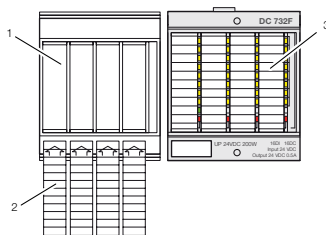

Name	Short Description	Article No.
TA523	Pluggable Marker Holder for I/O modules, 10 pcs. For labelling channels of I/O modules. The marking slips can be printed by users separately using a MS-Word based template.	1SAP180500R0001

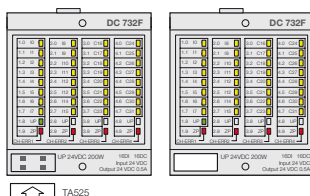

Name	Short Description	Article No.
TA525	White Labels, 10 pcs. For labelling CPU and I/O modules in AC 700F.	1SAP180700R0001

## 4.3.6 Power supplies

Name	Short Description	Article No.
CP-C 24 / 5.0	Power Supply, 5 A / 24 VDC Output 110-240 VAC / 100-350 VDC Input. For extended protection against accidental contact, mounting in a cabinet is recommended.	3BDH001040R0001
CP-C 24 / 10.0	Power Supply, 10 A / 24 VDC Output 110-240 VAC / 100-350 VDC Input. For extended protection against accidental contact, mounting in a cabinet is recommended.	3BDH001041R0001

## Technical data

Technical data CP-C 24 / 5.0 / 10.0	
Power dissipation	CP-C 24 / 5.0: typically < 15 W CP-C 24 / 10.0: typically < 29 W
Efficiency	Typically 88-89 %
MTBF	500.000 h
Dimensions W x H x D	CP-C 24 / 5.0: 56.5 x 130 x 137 mm / 2.22 x 5.12 x 5.39 inch CP-C 24 / 10.0: 90 x 130 x 137 mm / 3.54 x 5.12 x 5.39 inch
Weight	CP-C 24 / 5.0: approx. 0.96 kg / 2.11 lb CP-C 24 / 10.0: approx. 1.34 kg / 2.95 lb
Mounting	DIN-rail (DIN EN 50022) snap mechanism
Mounting position	Horizontal
Minimum distance between devices	Horizontal 10 mm (0.39 inch) Vertical 80 mm (3.15 inches)
Degree of Protection	IP 20
Protection class ( EN 61140)	I
<b>Environmental data</b>	
Ambient temperature range	
Operation	-25 °C (-13 °F)...+70 °C (158 °F)
Full load	0 °C (32 °F)...+60 °C (140 °F) (without derating)
Storage	-40 °C (-40 °F)...+85 °C (185 °F)
Damp heat (IEC/EN 60068-2-3)	93 % at +40 °C (104 °F), no condensation
Pollution category (EN 50178)	24 VDC
Climatic category (IEC/EN 60721)	3K3
<b>Isolation data</b>	
Insulation voltage	
Input	3 kVAC (type test), 1.2 kVAC (routine test)
Input / PE	1.5 kVAC (type test), 1.2 kVAC (routine test)
Output / PE	350 VAC (routine test)
<b>Input (L,N)</b>	
Rated input voltage $V_{IN}$	110 - 240 VAC
Input voltage range	85 - 264 VAC, 100 - 350 VDC (external fuse)

### Technical data CP-C 24 / 5.0 / 10.0

Frequency range AC	47 - 63 Hz
Current consumption at 110 - 240 VAC	Approx. 2.2 - 1.2 A
Power consumption	Typ. 135 W
Inrush current / I <sub>2t</sub> (cold start)	< 23 A / approx. 0.9 A <sup>2</sup> s
Power failure buffering at rated load	Min. 100 ms
Starting time after applying supply voltage	Typ. < 100 ms
Transient overvoltage protection	Varistors
Internal input fuse (apparatus protection), not accessible	CP-C 24 / 5.0: 4 A (slow-acting) CP-C 24 / 10.0: 6.3 A (slow-acting)
Discharge current for PE	< 3.5 mA

#### Output (L+, L+, L-, L-)

	Short-circuit, no-load and overload proof
Rated output voltage	24 VDC
Tolerance of the output voltage	±1 %
Adjustment range of the output voltage	22 – 28 V, factory setting 24 V ±0,5%
Rated output power	CP-C 24 / 5.0: 120 W CP-C 24 / 10.0: 240 W
Rated output current I <sub>r</sub> at T <sub>A</sub> < 60 °C (140 °F)	CP-C 24 / 5.0: 5 A CP-C 24 / 10.0: 10 A
Resistance to reverse feed	Approx. 35 VDC
Power Factor Correction (PFC)	Yes

#### Overload performance

Output characteristics	U/I curve with power reserve
Current limitation at short circuit	Approx. 11 A
Short-circuit protection	Approx. 11 A
Short-circuit protection	Continuous short-circuit stability
Overload protection	Thermal protection
Starting of capacitive loads	Unlimited

#### Standards

Product standard	IEC/EN 61204
Low Voltage Directive	2006/95/EC
EMC directive	2004/108/EC
Electrical safety	EN 50178, EN 60950, UL 60950, UL 508
Protective low voltage	SELV (EN 60950)

#### Electromagnetic Compatibility

Interference immunity	IEC/EN 61000-6-2
Electrostatic discharge (ESD)	IEC/EN 61000-4-2, Level 4 8 kV / 15 kV
Electromagnetic field	IEC/EN 61000-4-3, Level 3 10 V/m
Fast transient (Burst)	IEC/EN 61000-4-4, Level 4 4 kV
Powerful impulses (Surge)	IEC/EN 61000-4-5, Level 4 2 kV sym., Level 3, 3 kV non symmetric
HF line emission	IEC/EN 61000-4-6, Level 3 10 V
Interference emission	IEC/EN 61000-6-3
Electromagnetic field	IEC/CISPR 22, EN 55022, Class B
HF line emission	IEC/CISPR 22, EN 55022, Class B

## 4.3.7 Accessoires for power supplies

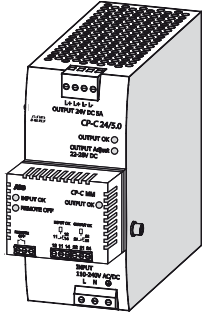

Name	Short Description	Article No.
CP-C MM	Messaging Module for CP-C, relay outputs  The message module CP-C MM indicates the correct function of the power supply unit via LEDs and energized output relays. The module will be plugged at the front side of the power supply.	3BDH001043R0001

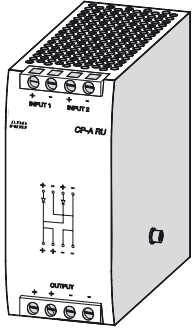

Name	Short Description	Article No.
CP-A RU	Redundancy Unit  If a fault occurs in the first power supply circuit, the total current requirement of all consumers can be completely covered by one power supply unit, and the output circuits are decoupled by means of the redundancy unit CP-A RU.	3BDH001044R0001

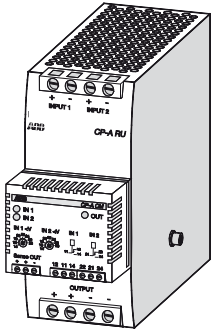

Name	Short Description	Article No.
CP-A CM	Control Module for Redundancy Unit CP-A RU  The control module CP-A CM indicates the presence of both input voltages of the CP-A RU via LEDs and energized output relays.	3BDH001045R0001





## 4.4 The controller AC 800F

The AC 800F controller has a modular structure. The CPU is designed as a backplane to which various modules – power supply units, Ethernet and fieldbus modules – can be attached in line with the application. On the fieldbus side, modules for PROFIBUS-DPV1, FOUNDATION Fieldbus HSE, MODBUS (master / slave, RTU or ASCII), IEC 60870-5-101 and CAN for Freelance Rack I/O are available.

The fieldbus line and the connected field devices are entirely configured and parameterized using the engineering tool Control Builder F. No further external tools are needed for configuration. Fieldbus and device configuration can be performed offline without connection to the field devices

In case of Profibus, field devices or slaves can be integrated into the system using device specific GSD<sup>1</sup> files or DTMs<sup>2</sup>. If for a certain device no DTM is available, generic DTMs can be used instead. Together with S900 remote I/O, HART variables are cyclically available as process data.

In the case of FOUNDATION Fieldbus, configuration takes place using specific CFF<sup>3</sup> or DD<sup>4</sup> files. Field devices are connected to H1 links, which in turn are connected via LD 800HSE linking devices to the high-speed HSE subnet. AC 800F controllers are connected to the HSE subnet, too.

Even a single AC 800F controller can be connected to both buses, Profibus and FOUNDATION Fieldbus at the same time. This makes it very convenient to run loops of an FF application using „control in the field“ technology, while at the same time gathering fast binary data via high-speed Profibus using remote I/Os.

### Mechanical design

The front panel connection technique of the AC 800F controller makes it exceptionally easy to assemble and to service.

Mounting on the wall can be achieved very easily.

All AC 800F modules are inserted into slots from the front and secured in position with screws. The modules are activated using a lock switch, which conceals the upper screw opening. The lock switch must be opened to reach the upper screw opening.

This signals the wish to remove the module from the CPU module, and the fieldbus is automatically shut down. As a result, the remote I/O and field device outputs have the opportunity to assume configured safety values, avoiding undefined states when the module is removed.

All modules are surrounded by metal casing when installed, which gives them optimum mechanical and electrical protection.

All casing materials used are simply screwed together, allowing them to be separated for future recycling. Last but not least, Freelance 800F has taken environmental protection into account by using a minimal amount of paint.

### Technical data

The AC 800F opens up the flexibility of fieldbus technology to the user. The AC 800F collects and processes diagnostic and process data from four fieldbus lines, which may be of different types.

The AC 800F is available in two versions:

- 4 MB for typically up to 400 I/Os
- 16 MB for typically up to 1000 I/Os

Up to 4 fieldbus modules can be plugged into the AC 800F. The communication with other controllers runs via Ethernet.

1) GSD = Device Master Data, abbreviation for the german term Gerätetammdaten. A GSD is the device database file (also called „device datasheet“)

2) DTM = Device Driver based on FDT technology

3) CFF= Capabilities File

4) DD= Device Description

AC 800F optionally provides several levels of redundancy:

- Controller redundancy with two identically equipped AC 800F controllers, which means full redundancy versus just a CPU-board redundancy. Possibility to mount the redundant unit far away from each other, e.g. in a fire proof room
- Cable redundancy for Profibus DP, by using external equipment (RLM01)

The availability of the control network can be increased by using ring topologies.

The data protection is made via battery backup.

**Features:**

- Controller with built-in fieldbus capability
- 4 high-speed fieldbus lines
- Supports different fieldbus types, even simultaneously:
  - PROFIBUS-DP, up to 12 MBd
  - FOUNDATION Fieldbus H1 (with LD 800HSE)
  - HART
  - Modbus
  - CAN (for Freelance Rack I/O)
- Easy engineering: fully integrated in Control Builder F
- One system-wide database for field devices shared by the control level and the Human System Interface
- Module recognition with factory and operational parameters
- Comprehensive diagnostics for predictive maintenance
- Compact, rugged design
- Front panel connectors
- DIN Rail (C-rail) or wall mounting for easy installation
- Ambient temperature 0-60 °C / 32-140 °F with temperature monitoring
- EMC certification according to EN50082
- Certification: CE, NAMUR, UL, EN61000-6-2, G3 ISA71.04

Details of system communication					
Bus type:	Twisted Pair (TP)	Fiber optic (FL)	Thin-Ethernet (Cheapernet)	Control network Full-Ethernet (Yellow Cable)	Station bus (CAN-Bus)
Max. length:	5 x 100 m 5 x 400 m for shielded TP	4500 m	5 x 185 m	5 x 500 m for Coax, 50 m for AUI	80 m, 400 m
Application:	Control network connection of Freelance 800F operator stations (for operation and observation), engineering station and controllers				Station bus and as connection to I/O units
Standard:	DIN/ISO 8802 Part 3 (IEEE 802.3) 10BASE-FL	DIN/ISO 8802 Part 3 10BASE-FL (IEEE 802.3)	DIN/ISO 8802 Part 3 (IEEE 802.3) 10BASE2	DIN/ISO 8802 Part 3 (IEEE 802.3) 10BASE5	ISO/DIN 11898
Transmission rate:	10 MBit/s	10 MBit/s	10 MBit/s	10 MBit/s	500 KBit/s for 80 m 100 KBit/s for 400 m

## Fieldbus modules

The AC 800F uses the fieldbus modules to collect and process real-time and diagnostic data. Up to four fieldbus modules can be mounted into one AC 800F.

The fieldbus modules have the following tasks and characteristics:

- Electrical isolation between the process and the Controller
- Status LEDs for the module status
- Independent fault detection and fault signaling
- Connection of the fieldbus segments and subnets

Details of the fieldbus modules		
Type	Channels	Function
CAN module	1	Connection of up to 5 Freelance I/O racks
Serial module	2	RS232 / RS422 / RS485 configurable for MODBUS, IEC 60870-5-101 telecontrol protocol
PROFIBUS module	1	Full-value PROFIBUS DPV1 Master
FF-HSE module	1	For the connection of up to 10 LD 800HSE Linking Devices with 10/100 MBaud autosense twisted pair connection

## Ethernet modules

Controllers, operator stations, and engineering stations communicate with each other via the Ethernet based control network. Ethernet modules for AC 800F establish the network connection.

Ethernet modules for the control network		
Type	Channels	Function
Ethernet module	1	Twisted pair connection 10 base T for connection to hubs or switches
Ethernet module	1	BNC connection 10 base 2 for thin coaxial cable (Cheapernet), 10 Mbit/s
Ethernet module	1	AUI connection 10 base 5 and 10 base FL via coupler

## Linking devices

As the AC 800F is equipped with high-speed connections to both PROFIBUS (PROFIBUS DP) and FOUNDATION Fieldbus (FF-HSE), the slower buses of the two fieldbus technologies (PROFIBUS PA and FF-H1) can be connected using intelligent linking devices. These devices allow to connect several slow buses to one fast bus, with the advantage that a lot more field devices can be connected to an AC 800F station than when the slow fieldbuses are connected directly.

## PROFIBUS DP / PA linking device

The PROFIBUS Power Hub is an interface between the PROFIBUS DP and the PROFIBUS PA. Combining a PROFIBUS Power Hub with a field barriers and segment protectors makes it possible to connect field devices to a control system, which are located in intrinsic safe areas. The field barriers and segment protectors can be connected to the non-intrinsically safe outputs (trunks) of PROFIBUS Power Hub. PROFIBUS Power Hub is a device from Pepperl+Fuchs.

## FOUNDATION Fieldbus linking device LD 800HSE

FOUNDATION Fieldbus (FF) is a fieldbus protocol based on international standards and designed for applications in the manufacturing industry, process automation and buildings automation. FF defines two communication profiles, H1 and HSE. The H1 profile, with a transmission rate of 31.25 kbit/s, is preferably used for direct communication between field devices in one link (H1 link).

The HSE profile, which is based on standard Ethernet and typically features a transmission rate of 100 Mbit/s, serves a backbone for the connection between H1 links.

The LD 800HSE connects the HSE Ethernet with the field devices on the H1 link side. They serve as a gateway between the field devices on the H1 link and the HSE subnet.

The LD 800HSE allows the client / server gateway communication and allows the link of function blocks between the H1 devices. LD 800HSE is also designed for redundancy.

## Fieldbus infrastructure

To protect fieldbus segments and links, appropriate fieldbus barriers can be used. For H1 links, power conditioners have to provide sufficient current.

Furthermore proper network switches can be used to connect AC 800F FF modules and several LD 800HSEs.

# Redundancy concept

## Controller redundancy

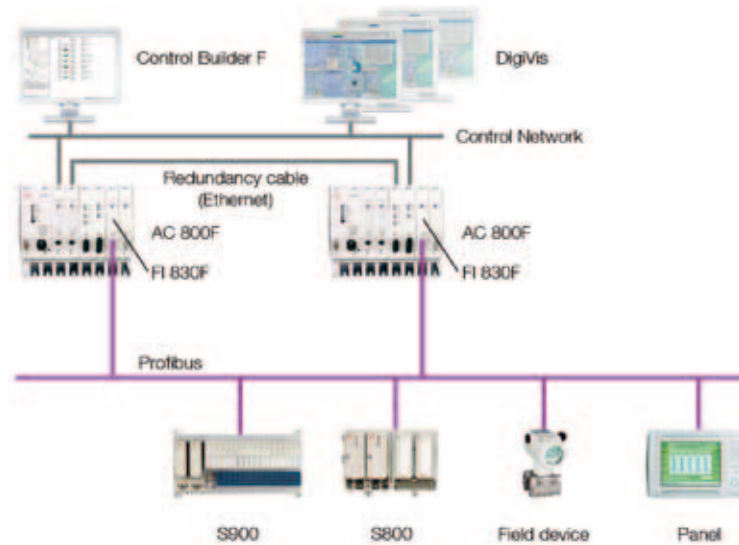

Controller redundancy can be achieved by installing two AC 800F. To ensure quick and smooth take-over by the secondary AC 800F in case the primary AC 800F fails, a dedicated redundancy communications link through the second Ethernet module makes sure that both AC 800F are always synchronized. All inputs and outputs are designed to support redundant operation.

## Profibus line redundancy

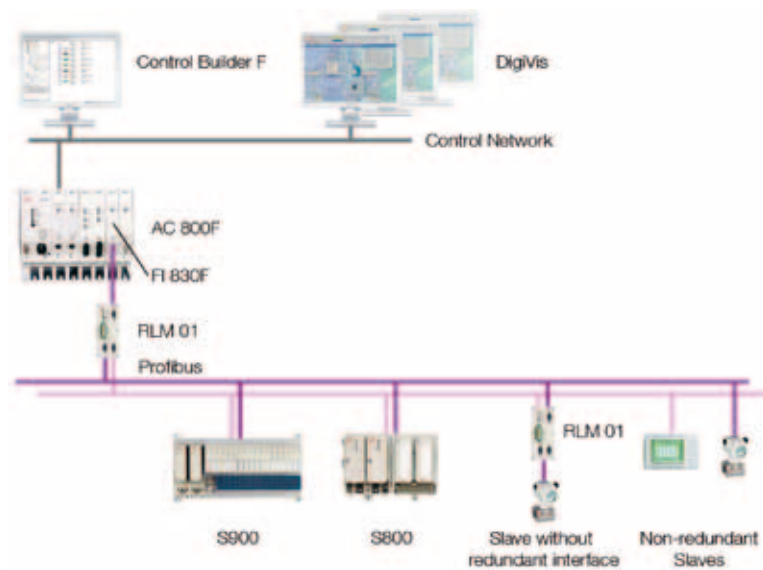

Using the Redundancy Link Module RLM 01 will do the conversion of one simple, non-redundant Profibus line into two reciprocally redundant lines. You can position the Redundancy Link Module RLM 01 directly after a Profibus module (master), before a bus segment with several slaves or before an individual slave. PROFIBUS stations with redundant couplers can be directly connected to the PROFIBUS set redundant by RLM 01. Stations with only one interface can be optionally assigned to the one or other line. For technical description dates of the Redundancy Link Module RLM 01 see document 3BDD011600R0201. An alternative solution to the Profibus line redundancy is to use a Fiber Optic Ring.

### Controller redundancy together with Profibus line redundancy

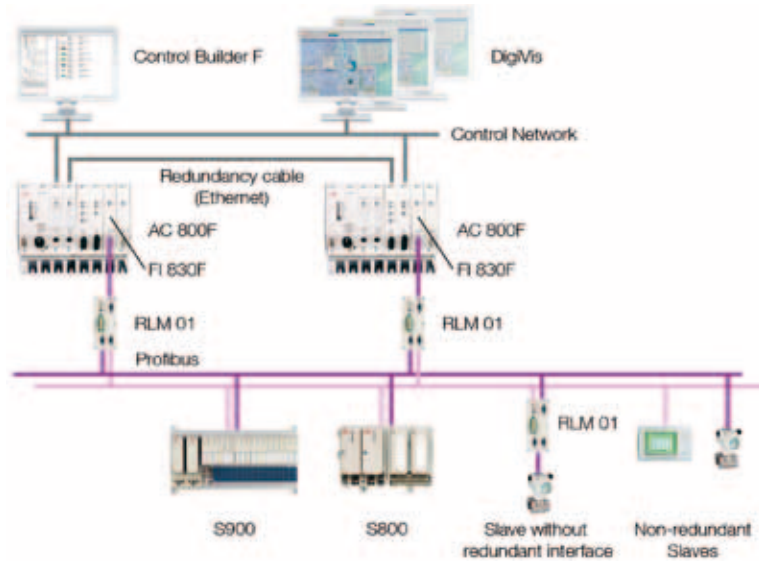

You can achieve the highest availability when doing both, controller redundancy and Profibus line redundancy by using two AC 800F with one RLM01 each. This topology combines the advantages of controller redundancy with the one of line redundancy as described in the above paragraphs.

### Controller redundancy together with FOUNDATION Fieldbus redundancy

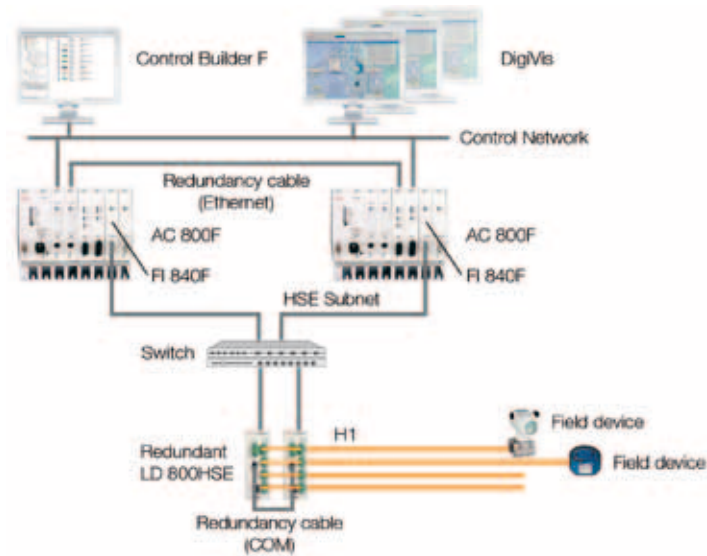

FOUNDATION Fieldbus redundancy can be achieved by installing two LD 800HSE. To ensure quick and smooth takeover by the secondary LD 800HSE in case the primary LD 800HSE fails, both devices are linked via a redundancy cable (COM).

## Environmental conditions

Permissible ambient temperature	0 °C - 60 °C / 32 °F - 140 °F
Permissible module internal temperature	0 °C - 70 °C / 32 °F - 158 °F (temperature monitoring on basic unit)
Temperature gradient	In operation: 1 °C (33.8 °F) / min, according to DIN IEC 68, Part 14 / EN 60068-2-14(11.99)
Transport and storage temperature	-25 °C - +85 °C / -13 °F / 185 °F
Permissible relative humidity	Non-condensing, ≤ 80 % annual average ≤ 95 % for 30 days per year maximum
Degree of humidity	RH-1, according to EN 61131-2: 1994 (IEC 1131-2)
Climatic category	KWF according to DIN 40040 (replaced by EN 60721-3-3 and EN 61709) 3K3 according to DIN IEC 721 / EN 60721-3-3
Degree of protection	For basic unit with module complement: IP20
G3 severity level	ISA71.04 G3 compliant (-Z variant)

## Electromagnetic compatibility (EMC)

Complies with the protection requirements of EMI directive 89/336/EEC of May 1989 and EMVG of Nov. 1992.	
Interference suppression	According to EN 55022 / 4.1988 DIN VDE 0878 Part 22 / 11.89, class B
Noise immunity	Basic standard: EN 50082, VDE 0839 - Part 82-2, EN 61000-6-2 Tested according to EN 61000-4; VDE 0847 Parts 1 to 6,8,11, Degree 3, are met with shielded communication cables The industrial standard to NAMUR 21 / 8.98 is met

## Electrical protection

Safety class	II
Overvoltage category	II for all connectors, pollution degree 2
Designed according to	IEC 1010-1 (1990 - 09); EN 61010-1 / 3.94 or DIN/EN 61010-Part 1 / 3.94 (VDE 0411-Part 1), CSAC 22.2, No. 1010-1 and No. 213 (Class I, Div 2), SIQ (CB Scheme 97NK2421), CSA / NTRL.
Module supply power	Extra low voltage with protective separation from other circuits which may be grounded according to DIN VDE 0100, Part 410-1.97/IEC 60364-4-41/10.92
Power supply SA 811F	Safety isolating transformer according to DIN VDE 0551, Part 1 (9.95); EN 60742 Optocoupler for protective separation against electrical shock (German standard VDE 0884 / 8.87)
Power supply SD 812F	No electrical separation!

## Shock and vibration data

Tested according to DIN IEC 68, Part 2-6, 2-27 / EN 60068-2-6, 2-27 (11.99)	
Transport	
Shock	30 g / 11 ms / 3 times to each axis Max. values for the individual modules. The values are valid for correct mounted modules.
In operation	
Vibration, 3x5 cycles	2 g / 0.15 mm / 5 - 150 Hz

## Power dissipation for the calculation of cooling system

The following table lists the anticipated power dissipation (heat dissipation) of individual AC 800F modules.

The data for the modules contain the combined power consumption from internal and external supply sources. For detailed information see the Mounting and Installation Instructions, AC 800F manual.

Module	Max. power dissipation
Basic unit PM 802F	
power supply SA 811F	20.8 W
power supply SD 812F	10.8 W
Basic unit PM 803F	
power supply SA 811F	26.8 W
power supply SD 812F	13.8 W
Ethernet module EI 811F	2.0 W
Ethernet module EI 812F	
without transceiver supply	2.3 W
with transceiver supply	4.9 W
Ethernet module EI 813F	1.2 W
CAN-module FI 810F	2.6 W
Serial module FI 820F	2.6 W
Profibus module FI 830F	2.8 W
FF / HSE module FI 840F	2.1 W
Battery module AM 811F	0.28 W



## 4.4.1 AC 800F, pre-assembled stations

Name	Short Description	Article No.
AC 800F - 4 MB, 115 / 230 VAC	With Ethernet 10BaseT, PROFIBUS module and Base Unit PM 802F  Incl. standard system test, battery SB 808F, mains cable TK 807F (open end). Slot assignment: P = SA 811F, E1 = EI 813F, F3 = FI 830F, E2, F1, F2, F4 = Front panel. Compliant to UL by using mains cable TK 809F (3BDM000212R1). Control Builder F V7.1SP2a or higher is mandatory.	3BDH000362R1
AC 800F - 4 MB, prepared for Redundancy, 24 VDC	With Ethernet 10BaseT, PROFIBUS module and Base Unit PM 802F  Incl. standard system test, 2 batteries SB 808F, 2 mains cable TK 802F (open end). Slot assignment: P = SD 812F, E1, E2 = EI 813F, F3 = FI 830F, F1, F2, F4 = Front panel. Control Builder F V7.1SP2a or higher is mandatory.	3BDH000363R1
AC 800F – 16 MB, 115 / 230 VAC	With Ethernet 10BaseT, PROFIBUS module and Base Unit PM 803F  Incl. standard system test, battery SB 808F, mains cable TK 807F (open end). Slot assignment: P = SA 811F, E1 = EI 813F, F3 = FI 830F, E2, F1, F2, F4 = Front panel. Compliant to UL by using mains cable TK 809F (3BDM000212R1). Control Builder F V7.1SP2a or higher is mandatory.	3BDH000103R1
AC 800F – 16 MB, prepared for Redundancy, 24 VDC	With Ethernet 10BaseT, PROFIBUS module and Base Unit PM 803F  Incl. standard system test, 2 batteries SB 808F, 2 mains cable TK 802F (open end). Slot assignment: P = SD 812F, E1, E2 = EI 813F, F3 = FI 830F, F1, F2, F4 = Front panel. Control Builder F V7.1SP2a or higher is mandatory.	3BDH000133R1

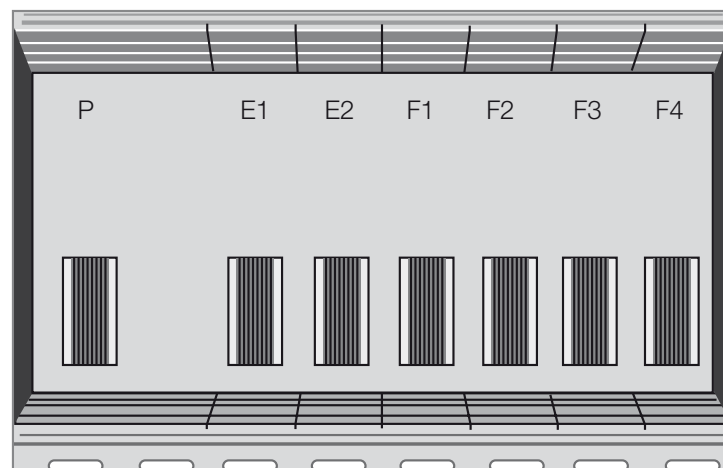
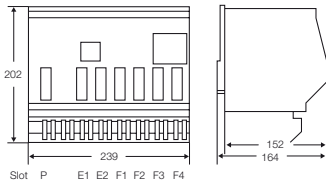

Figure 8: AC 800F Housing with slot assignment



## 4.4.2 AC 800F, base units PM 802F / PM 803F

Name	Short Description	Article No.
PM 802F	Base Unit 4 MB, battery-buffered RAM  Without operating system. The operating system has to be loaded during software installation. With special Contact Ledge RW 855F.	3BDH000002R1
PM 803F	Base Unit 16 MB, battery-buffered RAM  Without operating system. The operating system has to be loaded during software installation. With special Contact Ledge RW 855F. Control Builder F V7.1PS2a or higher is mandatory. Restrictions: The CPU performance is typically lower around 5% and maximally around 10% than with PM 802F Base Unit.	3BDH000530R1

The basic unit, PM 802F and respectively PM 803F, cyclically scans signals from the fieldbus lines via the corresponding fieldbus modules, processes these signals according the application programs installed by the user and sends appropriate signals to the fieldbus actuators via the fieldbus modules.

Controller redundancy can be achieved by using two AC 800F. To ensure quick and smooth takeover in milliseconds by the secondary AC 800F in case the primary AC 800F fails, a dedicated redundancy communications link through the second Ethernet module makes sure that both AC 800F are always synchronized. All inputs and outputs are designed to support redundant operation.

Data communication between AC 700F, AC 800F, the engineering and operator stations runs via the control network. Engineering station communications can involve new or updated configuration files being downloaded to the controller, or information about the connected modules being reported back. When fieldbus modules are installed or exchanged, the required configuration information is automatically updated.

Configuration and real-time process data is stored in the controllers. To safeguard this data in case of power loss, the RAM power is backed up with batteries located either on the Ethernet modules or on battery modules.

The PM 803F has more memory than the PM 802F and is therefor capable to handle larger projects.

### Features:

- Super Scalar RISC microprocessor (up to 150 MIPS)
- 16 K internal CPU cache RAM
- RAM memory with error detection and correction
  - PM 802F: 4 MB static
  - PM 803F: 16 MB synchronous dynamic
- Flash-EEPROM
  - PM 802F: 4 MB, 32-bit words
  - PM 803F: 8 MB, 32-bit words
- EEPROM, serial, 16 kbit
- Monitoring of the temperature inside the device
- Watchdog
- 4 slots for fieldbus modules
- 2 slots for Ethernet communications modules, 32-bit data bus, 10 Mbits/s
- Battery backup incl. battery watchdog
- G3 compliant Z variant available (see also Chapter „4.6 G3 compliant controllers“)

## Technical data

Technical data PM 802F / PM 803F	
CPU	CPU Intel® 80960HT25/75 32-bit RISC Super Scalar processor up to 150 MIPS
RAM	<b>PM 802F:</b> 4 MB static read / write memory battery back up  <b>PM 803F:</b> 16 MB synchronous dynamic read / write memory, battery back up
I/O scan cycle time	Selectable by configuration. Depends on the capabilities of the fieldbus module
Processing time for 1000 instructions	< 1.0 ms for binary and 16 bit arithmetic instructions < 2 ms for fixed point arithmetic instructions < 1.5 ms for 32 bit arithmetic instructions
Power consumption:	Basic unit only: PM 802F: max. 6.3 W PM 803F: max. 7.8 W depending on CPU usage and cycle time
Power supply	PM 802F / 803F 115 - 230 VAC SA 811F 24 VDC SD 812F
Max. power output	See power supply modules
Weight	1.6 kg / 3.3 lbs max. 5 kg / 11 lbs (fully assembled)
Dimensions	Width 239 mm, 9.4" Height 202 mm, 8" Depth 164 mm, 6.5"



## 4.4.3 Power supply SA 811F

Name	Short Description	Article No.
SA 811F	Power Supply 115 / 230 VAC To use together with PM 802F or PM 803F. Control Builder F V7.1SP2a or higher is mandatory.	3BDH000013R1

The AC 800F modules are supplied with 5 VDC / 5.5 A and 3.3 VDC / 6.5 A by SA 811F. The power supply has open-circuit, overload and sustained short-circuit protection. The electronically controlled output voltage provides high stability and low residual ripple.

In case of power loss  $\geq 5$  ms, the power supply module generates a power-fail signal. This signal is used by the CPU module to shut down operations and enter to a safe state of connected outputs of Remote I/Os. This is required for a controlled restart of the system and the user application when power is restored. The output voltage remains within its tolerance limits for at least another 15 ms. Altogether a mains voltage drop of 20 ms will be managed.

### Features:

- Input voltage 115 - 230 VAC (self adjusting), output is electrically isolated
- Power supply outputs provide: 5 VDC / 5.5 A and 3.3 VDC / 6.5 A
- Enhanced power-fail prediction and shutdown procedures
- LED indication for power supply status and operating status of the AC 800F
- Short circuit proof, current limited
- 20 ms backup energy for use in the event of primary power failure, according to NAMUR
- G3 compliant Z variant available (see also Chapter „4.6 G3 compliant controllers“)

## Technical data

Technical data SA 811F	
Input voltage	Alternating current 115 - 230 VAC Permissible range 90 - 260 VAC Frequency: 50 - 60 Hz (47 - 63 Hz)
Input current at nominal load	230 VAC: 275 mA 115 VAC: 541 mA
Rated input power	63 VA
Backup energy for the event of power failure	> 20 ms
Fuse	Subminiature fuse 2.5 AT, soldered
Output voltage	3.3 VDC ( $\pm 3\%$ ) typical 5 VDC ( $\pm 3\%$ ) typical
Output current	0.5 - 6.5 A to 3.3 V 0.5 - 5.5 A to 5.0 V
Current limit	Approx. 7.5 A Automatic return to normal operation after short circuit
Total output power	Max. 35 W
Weight	0.460 kg, 1.014 lbs

LED displays	Status	Description
Power	Green	Internal supply voltage is available
Failure	Off	Normal status
	Orange	Self test
	Flashing orange	Overtemperature occurred during operation
	Red	Hardware failure of the basic unit
	Flashing red	Software failure of the system
Run/Stop	Green	Processing active
	Flashing green	Process was stopped and is now started again
	Red	Processing inactive
	Flashing red	Process was active and is stopped now
	Orange	Self test
	Off	Software initialization
Prim/Sec	In case of redundancy please see the LEDs description in the manual "Mounting and Installation Instruction".	
	For non-redundancy the states are:	
	Orange	Self test
	Off	Normal status

Operator controls	Description
Run/Stop switch	Connected to LED
Toggle Prim/Sec	For redundancy. Toggles between primary and secondary AC 800F (operational on primary AC 800F only, and only if a secondary AC 800F is available)
Reset	Reset button press and hold > 4 s for coldstart

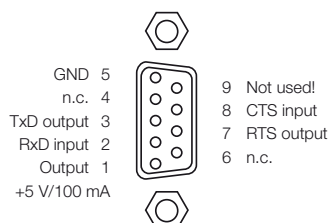

Front panel connections	Description
Power supply	One connector for 115 - 230 VAC input
Diag	For diagnostics and optional radio-controlled clock 9-pin male connector



## 4.4.4 Power supply SD 812F

Name	Short Description	Article No.
SD 812F	Power Supply 24 VDC To use together with PM 802F or PM 803F. Control Builder F V7.1SP2a or higher is mandatory.	3BDH000014R1

The AC 800F modules are supplied with 5 VDC / 5.5 A and 3.3 VDC / 6.5 A by SD 812F. The power supply has open-circuit, overload and sustained short-circuit protection. The electronically controlled output voltage provides high stability and low residual ripple.

In case of power loss  $\geq 5$  ms, the power supply module generates a power-fail signal. This signal is used by the CPU module to shut down operations and enter to a safe state. This is required for a controlled restart of the system and the user application when power is restored. The output voltage remains within its tolerance limits for at least another 15 ms. Altogether an input voltage drop of 20 ms will be managed..

### Features:

- Redundant input voltage 24 VDC, provides operation in accordance with NAMUR
- Power supply outputs provide: 5 VDC / 5.5 A and 3.3 VDC / 6.5 A
- Enhanced power-fail prediction and shutdown procedures
- LED indication for power supply status and operating status of the AC 800F
- Short circuit proof, current limited
- 20 ms backup energy for use in the event of primary power failure, according to NAMUR
- G3 compliant Z variant available (see also Chapter „4.6 G3 compliant controllers“)

## Technical data

Technical data SD 812F	
Input voltage	24 VDC, 2 redundant inputs permissible range 19.2 - 32.5 VDC
Input current at nominal load	1.7 A at 24 VDC
Rated input power	41 W
Backup energy for the event of power failure	> 20 ms
Fuse	For each supply: subminiature fuse 3.15 AT, soldered
Output voltage	3.3 VDC ( $\pm 3\%$ ) typical 5 VDC ( $\pm 3\%$ ) typical
Output current	0.5 - 6.5 A to 3.3 V 0.5 - 5.5 A to 5.0 V
Current limit	Approx. 7.5 A Automatic return to normal operation after short circuit
Total output power	Max. 35 W
Weight	0.460 kg, 1.014 lbs

LED displays	Status	Description
Power	Green	Internal supply voltage is available
Failure	Off	Normal status
	Orange	Self test
	Flashing orange	Overtemperature occurred during operation
	Red	Hardware failure of the basic unit
	Flashing red	Software failure of the system
Run/Stop	Green	Processing active
	Flashing green	Process was stopped and is now started again
	Red	Processing inactive
	Flashing red	Process was active and is stopped now
	Orange	Self test
	Off	Software initialization
Prim/Sec	In case of redundancy please see the LEDs description in the manual "Mounting and Installation Instruction".	
	For non-redundancy the states are:	
	Orange	Self test
	Off	Normal status

Operator controls	Description
Run/Stop switch	Connected to LED
Toggle Prim/Sec	For redundancy. Toggles between primary and secondary AC 800F (operational on primary AC 800F only, and only if a secondary AC 800F is available)
Reset	Reset button press and hold > 4 s for coldstart

Front panel connections	Description
Power supply	Two connectors for 24 VDC, automatic input selection when used with single power supply
Diag	For diagnostics and optional radio-controlled clock 9-pin male connector

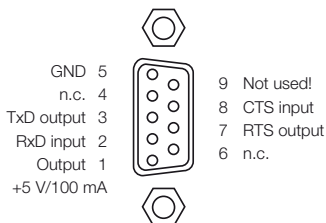



## 4.4.5 Ethernet interface EI 811F, 10Base2

Name	Short Description	Article No.
EI 811F	Ethernet Module 10Base2  To use together with PM 802F or PM 803F. Battery not included. Control Builder F V7.1SP2a or higher is mandatory.	3BDH000020R1

These communication modules provide Ethernet communications to the control network compliant with IEEE802.3 standard.

The communications module is compliant with 10Base2 (Cheapernet) for thin coax cable installations.

### Features:

- IEEE802.3 Ethernet standard
- Provides 10Base2 compliant communication
- 32-bit data bus
- Transmission rate 10 Mbit/s
- Direct memory access to main memory, < 4% CPU overhead for operation
- Optional battery for redundant battery backup of main memory
- G3 compliant Z variant available (see also Chapter „4.6 G3 compliant controllers“)

## Technical data

Technical data EI 811F		
Rated voltage	3.3 V / 5 V $\pm$ 3%, from CPU board	
Power consumption	Max. 2.0 W	
Thin Ethernet	10Base2	
RAM and real-time-clock buffering time	PM 802F:	PM 803F:
New battery inserted	$\geq$ 1.5 years	$\geq$ 10 days
After “Low” warning	$\geq$ 10 days	$\geq$ 5 hours
Battery	3.6 V lithium battery, 950 mAh (has to be ordered separately)	
Weight	Approx. 0.150 kg, 0.33 lbs (without battery)	



LED displays	Status	Description
Status	Off	No supply voltage, module is isolated
	Green	Power supply on, module identified and ready to operate as configured
	Orange	Power supply on, module identified and either: Normal transitory state after module startup
		Configuration mode of Boot Loader
	Orange flashing	Power supply on, module identified; module not connected to proper bus structure
	Red	Power supply on and either: Module not yet identified (normal for short time during module startup)
Error occurred during module test		
Battery (PM 803F)	Off	AC 800F is active, EI 811F not active => buffering from power supply module
		AC 800F is off (no watchdog of the batteries voltage): => buffering from Battery.
	Orange	During battery recovery or start-up phase
	Red	Warning: battery low, no battery inserted, insufficient electrical contact etc.
Battery (PM 802F)	Green	Battery inserted and data protection provided..
	Off	Sufficient buffer battery voltage
	Orange	Buffer battery not found or low (insufficient voltage)
Front panel connections		Description
Coax connector		10Base2



## 4.4.6 Ethernet interface EI 812F, AUI

Name	Short Description	Article No.
EI 812F	Ethernet Module AUI  To use together with PM 802F or PM 803F. Battery not included. Control Builder F V7.1SP2a or higher is mandatory.	3BDH000021R1

These communication modules provide Ethernet communications to the control network compliant with IEEE802.3 standard.

Communications module, to connect a commercial transceiver with AUI connector (15-pin female plug DIN 41652).

### Features:

- IEEE802.3 Ethernet standard
- Provides 10Base5 compliant communication via AUI
- 32-bit data bus
- Transmission rate 10 Mbit/s
- Direct memory access to main memory, < 4% CPU overhead for operation
- Optional battery for redundant battery backup of main memory
- G3 compliant Z variant available (see also Chapter „4.6 G3 compliant controllers“)

## Technical data

Technical data EI 812F		
Rated voltage	3.3 V / 5 V, ±3%, from CPU board	
Power consumption	Max. 4.9 W (2.3 W + PIN Transceiver)	
Full Ethernet	10Base5 via AUI / 10Base5 transceiver and AUI connection	
Fiber optic cable	10BaseFL via AUI / FO transceiver and AUI connection	
Transceiver feeding		
Rated voltage:	12 V, ± 5%	
Current requirement:	Typ. 250 mA	
RAM and real-time-clock buffering time	PM 802F:	PM 803F:
New battery inserted	≥ 1.5 years	≥ 10 days
After “Low” warning	≥ 10 days	≥ 5 hours
Battery	3.6 V lithium battery, 950 mAh (has to be ordered separately)	
Weight	Approx. 0.150 kg, 0.33 lbs (without battery)	

LED displays	Status	Description	
Status	Off	No supply voltage, module is isolated	
	Green	Power supply on, module identified and ready to operate as configured	
	Orange	Power supply on, module identified and either: Normal transitory state after module startup Configuration mode of Boot Loader	
		Orange flashing	Power supply on, module identified; module not connected to proper bus structure
		Red	Power supply on and either: Module not yet identified (normal for short time during module startup) Error occurred during module test
	Battery (PM 803F)	Off	AC 800F is active, EI 812F not active => buffering from power supply module  AC 800F is off (no watchdog of the batteries voltage) => buffering from battery
Orange		During battery recovery or start-up phase	
Red		Warning: battery low, no battery inserted, insufficient electrical contact etc	
Green		Battery inserted and data protection provided	
Battery (PM 802F)	Off	Sufficient buffer battery voltage	
	Orange	Buffer battery not found or low (insufficient voltage)	

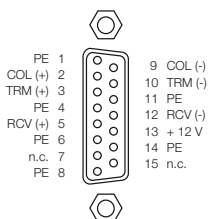

### Front panel connections

15-pin SUB-D socket with slide lock for AUI interface



## 4.4.7 Ethernet interface EI 813F, 10BaseT

Name	Short Description	Article No.
EI 813F	Ethernet Module 10BaseT (Twisted pair)  To use together with PM 802F or PM 803F. Battery not included. Control Builder F V7.1SP2a or higher is mandatory.	3BDH000022R1

These communication modules provide Ethernet communications to the control network compliant with IEEE802.3 standard.

Communications module, compliant with 10BaseT shielded Twisted Pair (STP, cable category 3, 4 or 5 advanced)

### Features:

- IEEE802.3 Ethernet standard
- Provides 10BaseT compliant communication (10Mbit)
- 32-bit data bus
- Transmission rate 10 Mbit/s
- Direct memory access to main memory, < 4% CPU overhead for operation
- Optional battery for redundant battery backup of main memory
- G3 compliant Z variant available (see also Chapter „4.6 G3 compliant controllers“)

## Technical data

Technical data EI 813F		
Rated voltage	3.3 V / 5 V, ±3%, from CPU board	
Power consumption	Max. 1.2 W	
STP	10BaseT cable category 3, 4 or 5 advanced	
RAM and real-time-clock buffering time	PM 802F:	PM 803F:
New battery inserted	≥ 1.5 years	≥ 10 days
After “Low” warning	≥ 10 days	≥ 5 hours
Battery	3.6 V lithium battery, 950 mAh (has to be ordered separately)	
Weight	Approx. 0.150 kg, 0.33 lbs (without battery)	

LED displays	Status	Description
Status	Off	No supply voltage, module is isolated
	Green	Power supply on, module identified and ready to operate as configured
	Orange	Power supply on, module identified and either:  Normal transitory state after module startup  Configuration mode of Boot Loader
	Orange flashing	Power supply on, module identified; module not connected to proper bus structure
	Red	Power supply on and either:  Module not yet identified (normal for short time during module startup)  Error occurred during module test
	Battery (PM 803F)	Off
Orange		During battery recovery or start-up phase
Red		Warning: battery low, no battery inserted, insufficient electrical contact etc
Green		Battery inserted and data protection provided
Battery (PM 802F)	Off	Sufficient buffer battery voltage
	Orange	Buffer battery not found or low (insufficient voltage)

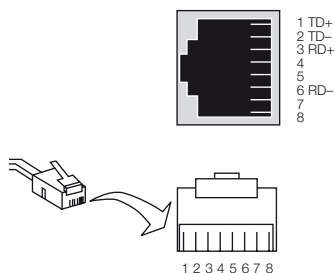

### Front panel connections

RJ-45 female connector (shielded)

There are two integrated LED's indicating the current communication status. The LEDs are not labeled but can be identified by their color. The upper yellow LED indicates the link state; the lower green LED indicates active communication.

LED 10BaseT link	Off	No active link. No communication possible.
	Static yellow	Active link. communication possible.
LED 10BaseT active	Off	No communication.
	Flashing green	Communication.



## 4.4.8 CAN-3 module FI 810F

Name	Short Description	Article No.
FI 810F	Fieldbus Module, CAN (triple channel) for rack I/O To use together with PM 802F or PM 803F.	3BDH000030R1

The FI 810F module provides connectivity to the Freelance rack I/O - up to 5 racks can be connected. It provides functionality according CAN 2.0 specification and supports baud rates up to 1 MBd. All interfaces are electrically isolated and support redundant operation in conjunction with a second AC 800F.

Only one FI 810F module may be plugged per AC 800F. The slot of the FI 810F module has to be F1.

### Features:

- 3-channel CAN modules
- Transmission rate: up to 1 MBd
- Module can be removed or inserted during operation
- Redundant operation, with redundant AC 800F
- G3 compliant Z variant available (see also Chapter „4.6 G3 compliant controllers“)

## Technical data

Technical data FI 810F	
Rated voltage	5 V, $\pm$ 3% from basic unit
Power consumption	1.6 W - 2.6 W, depending from communication
Channel supply:	
Rated voltage	5 V, $\pm$ 10%
Power consump. per channel	0.15 W, when idling 0.30 W, during communication
Weight	Approx. 0.145 kg, 0.32 lbs

LED displays	Status	Description
Status	Off	No supply power, module is isolated
	Green	Module is active and working properly
	Orange	Module has been identified by AC 800F, but has not yet been activated
	Red	Module powered up, but not yet identified, or an error has occurred
RxD0	Green	Receive data on channel 0
TxD0	Green	Transmit data on channel 0
RxD1	Green	Receive data on channel 1
TxD1	Green	Transmit data on channel 1
RxD2	Green	Receive data on channel 2
TxD2	Green	Transmit data on channel 2

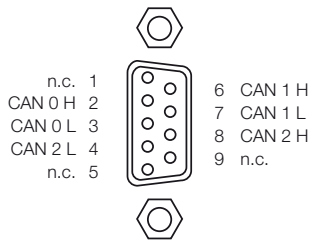

#### Front panel connections

CAN 3 9-pin female connector



## 4.4.9 Serial module FI 820F

Name	Short Description	Article No.
FI 820F	Fieldbus Module, Serial (dual channel) To use together with PM 802F or PM 803F.	3BDH000031R1

The FI 820F module provides connectivity to a variety of serial fieldbuses and serial protocols. Standard protocol is MODBUS

By using different connection cables the physical interface can easily be selected: RS485 (half duplex), RS422 (full duplex) or RS232. All interfaces are electrically isolated and support redundant operation in conjunction with a second AC 800F.

### Features:

- Provides 2 serial interfaces
- Transmission rates up to 38.4 kbaud configurable
- Physical interfaces RS485, RS422, RS232 selectable
- Electrical isolation
- Module can be removed or inserted during operation
- Redundant operation, with redundant AC 800F
- G3 compliant Z variant available (see also Chapter „4.6 G3 compliant controllers“)

## Technical data

Technical data FI 820F	
Rated voltage	5 V, $\pm$ 3% from basic unit
Power consumption	1.6 W - 2.6 W, appending from communication
Channel supply:	
Rated voltage	5 V, $\pm$ 10%
Power consump. per channel	0.15 W, when idling 0.30 W, during communication
Output voltage for termination (Vcc_Term)	
Rated voltage	5 V, $\pm$ 10%
Max. output current	20 mA
Weight	Approx. 0.145 kg, 0.32 lbs



LED displays	Status	Description
Status	Off	No supply power, module is isolated
	Green	Module is active and working properly
	Orange	Module has been identified by AC 800F, but has not yet been activated
	Red	Module powered up, but not yet identified, or an error has occurred
RxD0	Green	Receive data on channel 0
TxD0	Green	Transmit data on channel 0
RxD1	Green	Receive data on channel 1
TxD1	Green	Transmit data on channel 1

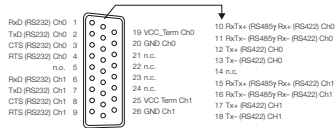

### Front panel connections

Serial - 26-pin female connector

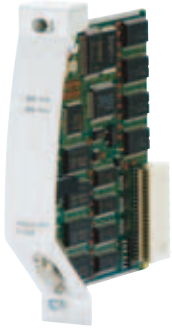

## 4.4.10 Profibus module FI 830F

Name	Short Description	Article No.
FI 830F	Fieldbus Module, PROFIBUS-DP To use together with PM 802F or PM 803F.	3BDH000032R1

The FI 830F module interfaces to the Profibus fieldbus. It provides functionality according to the PROFIBUS-DP V1 standard (DIN 19245 amendment 1) and supports baud rates up to 12 MBd.

The module is the master on the Profibus line and allows connecting up to 126 Profibus slaves. Configuration and parameterization is carried out completely with Control Builder F — no additional external configuration tools are required.

Line redundancy can be achieved using an external device (RLM 01) which drives two Profibus lines in parallel. In conjunction with a second AC 800F the module can also operate in a redundant-master mode without limiting any other feature.

### Features:

- PROFIBUS-DP Module (DIN 19245)
- Transmission rate up to 12 MBd
- Supports up to 126 slaves
- Physical interface: RS485
- Electrical isolation
- Shared memory (256 KB) onboard, to minimize the use of basic unit memory
- Module can be removed or inserted during operation
- Redundant operation, with redundant AC 800F
- G3 compliant Z variant available (see also Chapter „4.6 G3 compliant controllers“)

## Technical data

Technical data FI 830F	
Power consumption	In the active state, depends on the communication cycle time: 2.8 W
Max. output current	20 mA for bus termination / repeater supply
Output voltage	5 V, ± 5%
Overvoltage protection	+7.5 V / -5 V either transmission line to GND
Weight	Approx. 0.150 kg, 0.33 lbs

LED displays	Status	Description
Status	Off	No supply power, module is isolated
	Green	Module is active and working properly
	Orange	Module has been identified by AC 800F, but has not yet been activated
	Red	Module powered up, but not yet identified, or an error has occurred
Busy	Off	Module is in passive state on the Profibus
	Green	Module has token and, thus, is acting as the master

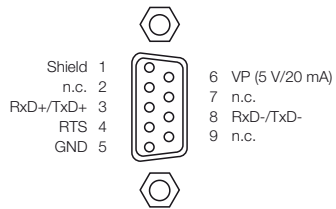

### Front panel connections

Profibus 9-pin female connector (DIN 41652)



## 4.4.11 FF / HSE module FI 840F

Name	Short Description	Article No.
FI 840F	Fieldbus Module, FF HSE  To use together with PM 802F-Z or PM 803F-Z. UL pending. Control Builder F V7.1SP2a or higher is mandatory.	3BDH000033R1

The FI 840F is a high speed ethernet fieldbus module designed for fast data exchange in production engineering with decentralized peripherals.

The FF / HSE module FI 840F is a Fieldbus Foundation®-(FF)-Master. Using the Control Builder F it is possible to configure diverse Fieldbus Foundation®-devices.

The FF / HSE module FI 840F is designed to connect the AC 800F to a FF / HSE network. It can be mounted on slots F1...F4. It is used if high transmission rates are required or shall be made available for future use. FF / HSE wiring is always a point-to-point connection. Therefore a networks with more than two nodes always requires network switches or hubs.

### Features:

- ARM-CPU with integrated Ethernet controller, 32-bit data bus, 32-bit address bus
- Flash EPROM for module CPU and protocol software
- Software / firmware update without EPROM exchange
- Separate memory for module CPU
- Shared memory for data exchange between main processor and module CPU. Data protection by parity check
- Automatic detection if 10BaseT or 100BaseTX is connected
- Electrical isolation for TP interface
- ESD protector on RJ45 socket
- Serial interface / Manchester encoder for generating a serial bit stream
- EEPROM for configuration data and diagnostic data memory independent from battery buffering
- Isolator for electrical isolation of the bus signals
- RJ45 connector with two link LEDs
- G3 compliant Z variant available (see also Chapter „4.6 G3 compliant controllers“)

## Technical data

Technical data FI 840F	
Rated voltage	5 V ± 3% 3.3 V ± 3 % and 2.5 V ± 5 %
Power consumption	In the active state, 1.4 W - 2.1 W depending on communications load
Module memory	8 MBytes synchronous dynamic RAM
Shared memory	1 MByte synchronous static RAM used for data exchange between CPU board and module
Firmware memory	2 MByte Flash EPROM, 32-bit word length, capable of programming in the system and direct programming from AC 800F CPU board
EEPROM	Serial 16 kbit EEPROM, write cycles ≥ 10 <sup>7</sup> buffering time ≥ 10 years
Weight	Approx. 0.150 kg, 0.33 lbs

Static characteristics	
Power consumption	Max. 2.1 W
Medium	100BaseTx cable, category 5
Max. segment length	100 m
Max. number of nodes per segment	2

Dynamic characteristics	
Transmission rate 10 Mbit/s or 100 Mbit/s	

LED displays	Status	Description
State	Off	No voltage applied, module is separated
	Green	Power on, module is identified and ready for operation according to the configuration
	Orange	Power on, Module has been identified by AC 800F, Intermediate state during start-up Configuration mode of the boot loader
	Flashing orange	Power on, module has been identified by AC 800F. Module is not connected to corrected bus physics
	Red	Power on Module not yet identified (on a short-term basis during startup) An error has occurred during module test

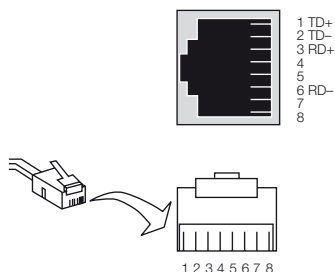

Front panel connections		
RJ-45 female connector (shielded) There are two integrated LEDs indicating the current communication status. The LEDs are not labeled but can be identified by their color. The upper yellow LED indicates the transmission rate, the lower green LED indicates the communication state.		

LED FF / HSE Speed	Off	Module has detected 10 Mbit/s data connection.
	Static yellow	Module has detected 100 Mbit/s data connection
LED FF / HSE Link	Off	No active link, neither 10Mbit nor 100 Mbit. No communication possible.
	Static green	Active link. Communication possible. No data transfer.
	Flashing green	Active link. Communication possible.



## 4.4.12 AC 800F auxiliary module

Name	Short Description	Article No.
AM 811F	Battery Module	3BDH000050R1
	To use together with PM 802F and PM 803F Battery not included SB 808. Control Builder F V7.1SP2a or higher is mandatory.	

The battery module can be used in non-redundant controllers with only one ethernet module to increase the buffering time.

### Features:

- Provides battery backup
- Enables redundant battery energy backup on the AC 800F
- G3 compliant Z variant available (see also Chapter „4.6 G3 compliant controllers“)

## Technical data

Technical data AM 811F		
Rated voltage	3.3 V / 5 V $\pm$ 3%, from CPU board	
Power consumption	Approx. 0.28 W	
Battery	3.6 V lithium battery, 950 mAh (included in delivery)	
Low battery signaling	$\leq$ 3.2 V	
RAM and real-time-clock buffering time	PM 802F:	PM 803F:
New battery inserted	$\geq$ 1.5 years	$\geq$ 10 days
After “Low“ warning	$\geq$ 10 days	$\geq$ 5 hours
Weight	Approx. 0.150 kg, 0.33 lbs without buffer battery Approx. 0.170 kg, 0.375 lbs with buffer battery	

LED displays	Status	Description
Status	Off	No supply voltage, module is isolated
	Green	Power supply on, module identified and ready to operate as configured
	Orange	Power supply on, module identified and either:  Normal transitory state after module startup  Configuration mode of Boot Loader
	Red	Module power supply on and either:  Module not yet identified (normal for short time during module startup)  Error occurred during module test
Battery (PM 803F)	Off	AC 800F is active, AM 811F not active => buffering from power supply module  AC 800F is off (no watchdog of the batteries voltage): => buffering from Battery.
	Orange	During battery recovery or start-up phase
	Red	Warning: battery low, no battery inserted, insufficient electrical contact etc.
	Green	Battery inserted and data protection provided..
Battery (PM 802F)	Off	Sufficient buffer battery voltage
	Orange	Buffer battery not found or low (insufficient voltage)

## 4.5 AC 800F accessories

### 4.5.1 Battery holder

Name	Short Description	Article No.
SY 809F	Battery Holder Without battery SB 808F.	3BDH000042R1

### 4.5.2 Front panel

Name	Short Description	Article No.
AM 895F	Front Panel, 4 pcs Covering unused slots of AC 800F.	3BDH000044R1

### 4.5.3 Supply cables

Name	Short Description	Article No.
TK 807F	Supply Cable 115 / 230 VAC, ferrules, 2 m For SA 811F.	3BDM000210R1
TK 808F	Supply Cable 115 / 230 VAC, Euro plug, 2 m For SA 811F.	3BDM000211R1
TK 809F	Supply Cable 115 / 230 VAC, US plug, 2 m For SA 811F.	3BDM000212R1
TK 802F	Supply Cable 24 VDC, ferrules, 2 m For SD 812F.	3BDM000213R1

### 4.5.4 Protection

Name	Short Description	Article No.
RW 857F	Contact Ledge	3BDM000192R1



## 4.5.5 CAN cable and serial cable

Name	Short Description	Article No.
TK 831F	CAN Cable (3 channel), integral connectors, 0.5 m  3 x 2 x 0.25 mm <sup>2</sup> , Identical with DFA 031. Connection FI 810F to Terminal Block TB 870F.	3BDM000100R1
TK 811F	CAN Cable, open end, ferrules, 3 m  3 x 2 x 0.25 mm <sup>2</sup> , Identical with DFA 011. Connection FI 8x0F to Terminal Block TB 870F.	3BDM000103R1
TK 817F	CAN Cable, open end, ferrules, 100 m  3 x 2 x 0.5 mm <sup>2</sup> , Identical with DFA 007.	3BDM000356R1
TK 821F	Serial Cable (2 channel), integral connectors, 0.5 m  Identical with DFA 021. Connection FI 820F to Terminal Block TB 870F.	3BDM000150R1

## 4.5.6 Miscellaneous

Name	Short Description	Article No.
TB 870F	Terminal Block, for serial interface	3BDM000160R1
RW 856F	Mounting Accessory, for enforced wall mounting	3BDM000190R1

## 4.6 G3 compliant controllers

G3 compliant components are protected with a special coating against corrosive gases.

The following Freelance 800F ISA71.04 G3 compliant components are available from stock under the same conditions as any ordinary Freelance 800F component. G3 compliance for AC 800F requires exclusively use of -Z components. AM 810F-Z serves for closing unused slots and the behind system plug.

G3 compliant components are identified by „Z“ added to the module name, for example AC 800F-Z-4 MB

### 4.6.1 Pre-assembled G3 compliant stations

Name	Short Description	Article No.
AC 800F-Z - 4 MB, 115 / 230 VAC	With Ethernet 10BaseT, PROFIBUS module and Base Unit PM 802F-Z  Incl. standard system test, battery SB 808F, mains cable TK 807F (open end). Slot assignment: P = SA 811F-Z, E1 = EI 813F-Z, F3 = FI 830F-Z, E2, F1, F2, F4 = AM 810F-Z. Coated and G3 compliant version. Compliant to UL by using mains cable TK 809F (3BDM000212R1). Control Builder F V7.1SP2a or higher is mandatory.	3BDH000362Z1
AC 800F-Z - 4 MB, prepared for Redundancy, 24 VDC	With Ethernet 10BaseT, PROFIBUS module and Base Unit PM 802F-Z  Incl. standard system test, 2 batteries SB 808F, 2 mains cable TK 802F (open end). Slot assignment: P = SD 812F-Z, E1, E2 = EI 813F-Z, F3 = FI 830F-Z, F1, F2, F4 = AM 810F-Z. Coated and G3 compliant version. Control Builder F V7.1SP2a or higher is mandatory.	3BDH000363Z1
AC 800F-Z - 16 MB, 115 / 230 VAC	With Ethernet 10BaseT, PROFIBUS module and Base Unit PM 803F-Z  Incl. standard system test, battery SB 808F, mains cable TK 807F (open end). Slot assignment: P = SA 811F-Z, E1 = EI 813F-Z, F3 = FI 830F-Z, E2, F1, F2, F4 = AM 810F-Z. Coated and G3 compliant version. Compliant to UL by using mains cable TK 809F (3BDM000212R1). Control Builder F V7.1SP2a or higher is mandatory.	3BDH000103Z1
AC 800F-Z - 16 MB, prepared for Redundancy, 24 VDC	With Ethernet 10BaseT, PROFIBUS module and Base Unit PM 803F-Z  Incl. standard system test, 2 batteries SB 808F, 2 mains cable TK 802F (open end). Slot assignment: P = SD 812F-Z, E1, E2 = EI 813F-Z, F3 = FI 830F-Z, F1, F2, F4 = AM 810F-Z. Coated and G3 compliant version. Control Builder F V7.1SP2a or higher is mandatory.	3BDH000133Z1

## 4.6.2 AC 800F-Z base units

Name	Short Description	Article No.
PM 802F-Z	Base Unit 4 MB, battery-buffered RAM  Coated and G3 compliant version. Without operating system. The operating system has to be loaded during software installation. With special Contact Ledge RW 855F.	3BDH000002Z1
PM 803F-Z	Base Unit 16 MB, battery-buffered RAM  Coated and G3 compliant version. Without operating system. The operating system has to be loaded during software installation. With special Contact Ledge RW 855F. Control Builder F V7.1SP2a or higher is mandatory. Restrictions: The CPU performance is typically lower around 5% and max. around 10% than with PM 802F-Z Base Unit.	3BDH000530Z1

## 4.6.3 AC 800F-Z power supplies

Name	Short Description	Article No.
SA 811F-Z	Power Supply 115 / 230 VAC  Coated and G3 compliant version. To use together with PM 802F-Z or PM 803F-Z. Control Builder F V7.1SP2a or higher is mandatory.	3BDH000013Z1
SD 812F-Z	Power Supply 24 VDC  Coated and G3 compliant version. To use together with PM 802F-Z or PM 803F-Z. Control Builder F V7.1SP2a or higher is mandatory.	3BDH000014Z1

## 4.6.4 AC 800F-Z ethernet interface modules

Name	Short Description	Article No.
EI 811F-Z	Ethernet Module 10Base2  Coated and G3 compliant version. To use together with PM 802F-Z or PM 803F-Z. Battery not included. Control Builder F V7.1SP2a or higher is mandatory.	3BDH000020Z1
EI 812F-Z	Ethernet Module AUI  Coated and G3 compliant version. To use together with PM 802F-Z or PM 803F-Z. Battery not included. Control Builder F V7.1SP2a or higher is mandatory.	3BDH000021Z1
EI 813F-Z	Ethernet Module 10BaseT (Twisted pair)  Coated and G3 compliant version. To use together with PM 802F-Z or PM 803F-Z. Battery not included. Control Builder F V7.1SP2a or higher is mandatory.	3BDH000022Z1

## 4.6.5 AC 800F-Z fieldbus interface modules

Name	Short Description	Article No.
FI 810F-Z	Fieldbus Module, CAN (triple channel) for Rack I/O  Coated and G3 compliant version. To use together with PM 802F-Z or PM 803F-Z.	3BDH000030Z1
FI 820F-Z	Fieldbus Module, Serial (dual channel)  Coated and G3 compliant version. To use together with PM 802F-Z or PM 803F-Z.	3BDH000031Z1
FI 830F-Z	Fieldbus Module, PROFIBUS-DP  Coated and G3 compliant version. To use together with PM 802F-Z or PM 803F-Z.	3BDH000032Z1
FI 840F-Z	Fieldbus Module, FF HSE  Coated and G3 compliant version. To use together with PM 802F-Z or PM 803F-Z. Control Builder F V7.1SP2a or higher is mandatory.	3BDH000033Z1

## 4.6.6 AC 800F-Z auxiliary modules

Name	Short Description	Article No.
AM 810F-Z	Cover Module  G3 compliant station assembly requires AM 810F-Z for closing unused slots and the behind system plug.	3BDH000622Z1
AM 811F-Z	Battery Module  Coated and G3 compliant version. To use together with PM 802F-Z and PM 803F-Z. Without battery SB 808. Control Builder F V7.1SP2a or higher is mandatory.	3BDH000050Z1

## 4.7 Common accessories for AC 800F / 800F-Z

### 4.7.1 Clips and clamps

Name	Short Description	Article No.
RY 885F	Grounding Strap, 2 pcs. Identical with DSU 485.	3BDM000169R1
TV 821F	Clip for shielding, 6 mm, 5 pcs. Identical with DSU 421.	3BDM000171R1
TV 822F	Clip for shielding, 16 mm, 5 pcs. Identical with DSU 422.	3BDM000172R1
TV 823F	Clip for shielding, 16..25 mm, 5 pcs. Identical with DSU 423.	3BDM000173R1
TV 824F	Clip for shielding, 23..35 mm, 5 pcs. Identical with DSU 424.	3BDM000174R1
TV 825F	Clip for shielding, 25..40 mm, 5 pcs. Identical with DSU 425.	3BDM000175R1
TV 831F	Clamp-type terminal, 3..10 mm, 5 pcs. Identical with DSU 426.	3BDM000180R1
TV 832F	Clamp-type Terminal, 16...20 mm, 5 pcs. Identical with DSU 427.	3BDM000181R1

### 4.7.2 Battery

Name	Short Description	Article No.
SB 808F	Battery for RAM buffering, 2 pcs. Identical with DSU 08.	3BDM000199R1

### 4.7.3 Protection

Name	Short Description	Article No.
TY 800F	Protective for SUB-D 9-pole, 2 pcs. Identical with DSU 80.	3BDM000310R1
TY 802F	Protective for "AUI", 5 pcs. Identical with DSU 82.	3BDM000311R1
TY 803F	Protective for "BNC", 1 piece Identical with DSU 83.	3BDM000312R1
TY 805F	Protective for SUB-D 15 / 26-pole, 5 pcs. Identical with DSU 85.	3BDM000313R1

### 4.7.4 Cables

Name	Short Description	Article No.
TK 891F	Diagnostics Cable, 5 m Identical with DSU 141.	3BDM000201R1
TK 890F	Diagnostics Cable, 10 m Identical with DSU 141.	3BDM000202R1

### 4.7.5 Auxiliary power supply

Name	Short Description	Article No.
DPW 02	Power Supply, 24 VDC - 24 VDC, 5 A 74 x 30 x 120 (W, H, D)	8018277M
DPW 03	Power Supply, 115 / 230 VAC - 24 VDC, 5 A 65 x 125 x 103 (W, H, D)	8018544M
DSU 45	Mains Cable for 230 VAC, Euro plug, 1.5 m	0339140M
DSU 45	Mains Cable for 230 VAC, Euro plug, 5 m	0339141M





# Chapter 5 Remote I/Os

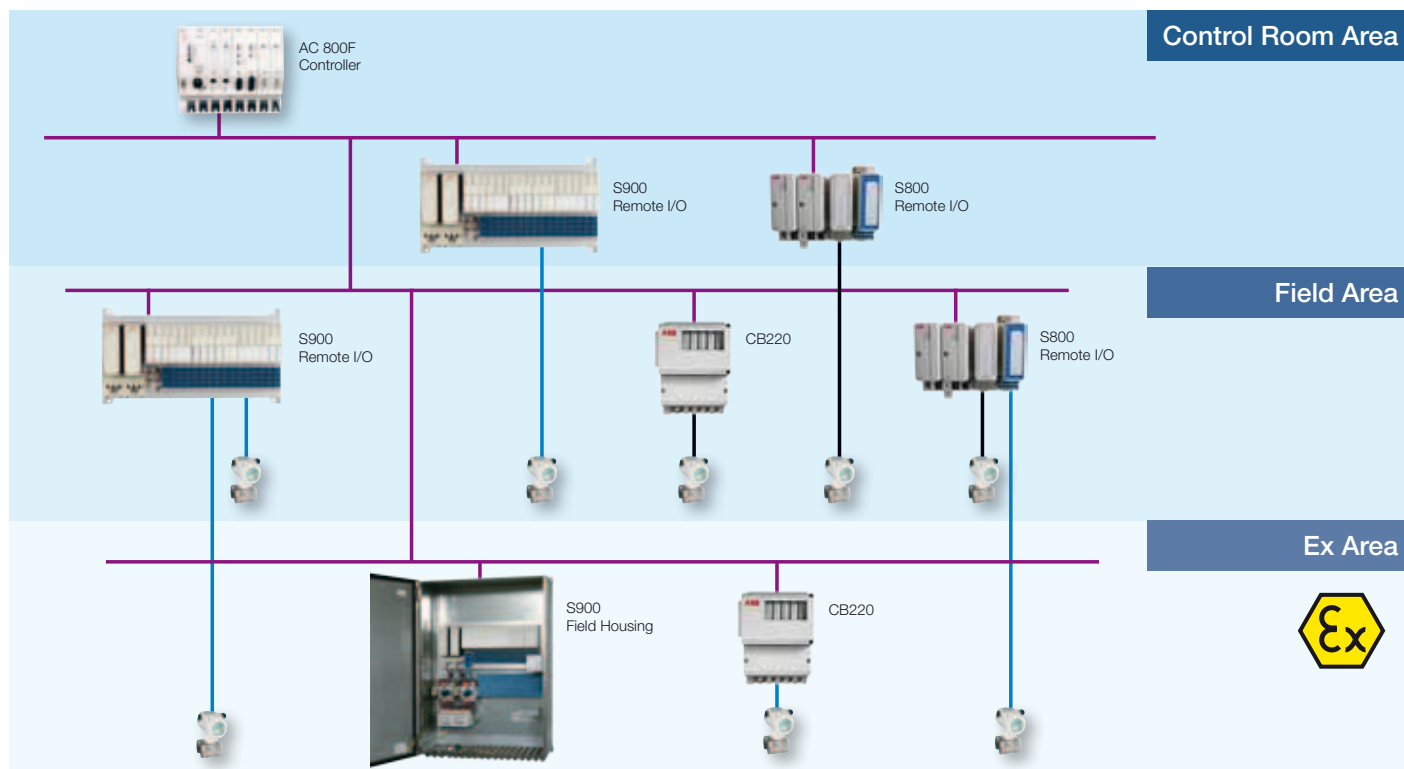

The following chapter will give you a brief overview about the Remote I/O systems S800 and S900. For more detailed information please see the data sheets.

The picture above shows a possible Profibus topology.

The controllers are assembled in the control room. Remote I/O systems S800 and S900 can be assembled in the control room, directly in the field or locally in the field in hazardous area, depending on the customer's wishes. Field devices are connected to the remote I/O systems.

Remote I/O systems can also be mounted locally in the field, near field devices. This type of installation reduces the costs for cabling from the field device to the system.

On-site assembly of the S800 and S900 remote I/O systems is easy, as only a single cable is required for Profibus communication and just one suitable field housing is needed for mounting. This field housing usually has the IP66 degree of protection. Other devices such as fiber optic couplers, pneumatic valves, terminals, terminal blocs or additional electronic devices can also be mounted in such a field housing. This reduces both design, engineering and cabling costs.

In order for devices to be installed in hazardous areas, extra regulations and functional rules need to be considered in addition to the usual engineering rules.

All devices which are used in hazardous area have to be certified. The devices shall have a certificate for either Zone 1 or Zone 2.

The S900 remote I/O system is suitable for installation in hazardous areas.

Series	Assembly	Field devices / signals	Hazardous area approval
S series	in Zone 1	in Zones 2, 1, and 0 (intrinsically safe signals)	ATEX Zone 1
B series	in Zone 2	in Zones 2, 1, and 0 (intrinsically safe signals)	ATEX Zone 2
N series	in safe areas	in safe areas	no



## 5.1 S800 Remote I/O

S800 I/O is a comprehensive, distributed and modular process I/O system that communicates with parent controllers via PROFIBUS. Thanks to its broad connectivity, the system is able to communicate with a wide range of process control systems from both ABB and other suppliers. By permitting installation in the field, close to sensors and actuators, S800 I/O greatly reduces the installation cost by reducing the cost of cabling. It is possible to exchange modules and reconfigure the system during operation. Redundancy options allow a high degree of availability.

With its cost-effective design and just 59 mm depth installation, S800L I/O modules are the perfect choice for PLC applications. Robust mechanics, one-piece handling, easy mounting and smart connections save your time in all phases of installation.

Furthermore S800L I/O is a subset of the comprehensive S800 I/O system. Consequently S800L I/O has the same full-featured signal interfacing and high availability as the S800 I/O system.

### 5.1.1 Communication

#### 5.1.1.1 Field communication interfaces

Name	Short Description	Article No.
CI801	PROFIBUS DP-V1 Communication Interface  Including: 1x Power Supply Connector 1x TB807 ModuleBus Terminator The basic system software loaded in CI801 does not support the following I/O modules: DI830, DI831, DI885, AI880A, DI880 and DO880.	3BSE022366R1
CI801 Engineering kit	SW 1.2  Including: 1x CD with GSD file, Memory Maps and Release Note. 1x Reference Manual Memory Maps for CI801.	3BSE038540R1200
CI810B	AF100 Field Communication Interface  2x AF100 Twisted Pair Connections. Including: 1x Power Supply Connector 1x TB807 ModuleBus Terminator The basic system software loaded.	3BSE020520R1
CI820V1	S800 Redundant FCI  1x AF100 Modem, 0.5 FEPROM, 0.5MB SRAM, 16MHz. Two CI820 must be ordered for redundancy. One item A070 must also be ordered with this item. The basic system software is loaded.	3BSE025255R1

Name	Short Description	Article No.
CI840A	Profibus DP-V1 Communication Interface. For 1+1 redundant operation.  Two CI840A and one TU847 or one TU846 must be ordered. The basic system software loaded in CI840 does not support the following I/O modules: DI830, DI831, DI885, AI880A, DI880, DO880 and ABB Drives.	3BSE041882R1
CI840 Engineering kit	SW 4.0  Including: 1x CD with GSD file, Memory Maps and Release Notes. 1x Reference Manual Memory Maps for CI840.	3BSE031694R4000
TB815	Interconnection Unit  Including: 1x TB807 ModuleBus Terminator. Used for interconnection of two CI820.	3BSE013204R1
TU846	Module Termination Unit, MTU, for 1+1 CI840. Support for redundant I/O  Vertical mounting of modules. Including: 1x Power Supply Connector 2x TB807 ModuleBus Terminator.	3BSE022460R1
TU847	Module Termination Unit for 1+1 CI840. Support for non-redundant I/O  Vertical mounting of modules. Including: 1x Power Supply Connector 1x TB807 ModuleBus Terminator.	3BSE022462R1
Front label set	FCI / AC 70 / TB  Sheet with 12 labels. For CI810, CI820, CI830, and TB820.	3BSC970089R1
Label set, item design	FCI / AC 70 / TB  Sheet with 40 labels. For CI810, CI820, CI830, and TB820.	3BSC970091R1
Mounting kit	For vertical mounting of CI801, CI840 and TB840 on a vertical DIN rail	3BSE040749R1
Mounting profile 1800	2 DIN rails and 1 cable duct  DIN rail length : 1650mm + 210mm (65") + (8.3")	3BSE049768R1
Al-profile	Al-profile with DIN Rail and Cable Duct, mounting 465 mm (19")  DIN rail length 429mm (16,9")	3BSE022255R1
Al-profile	Al-profile with DIN Rail and Cable Duct for RM550, mounting 592 mm (24")  DIN rail length 556mm (21,9")	3BSE022256R1

## 5.1.1.2 Upgrade kit and tool cables

Upgrading of CI801, CI810, CI820, CI830, CI840 or CI840A to latest software version are available for download from ABB Library/Solutions Bank.

Item A190 is cable connecting a PC to CI810, CI820 and CI830 for download of software. Item A195 is cable connecting a PC to CI840 or CI840A for download of software. CI801 requires items A195 and A197 for download of software

Name	Short Description	Article No.
TK527V030	Interface cable L = 3 m. DE9 pin to DE9 socket. For connection of CI810, CI820 and CI830 to PC.	3BSC950004R1
TK212A	Tool cable RJ45 (male) to Dsub-9 (female), length 3 m. RJ45 8P8C plug (with shell). Cable : UL2464 26 AWG x 8C.	3BSC630197R1
FS801K01	Service adapter kit Including: 1x Service adapter FS801 1x cable TK802 For connection of CI801 to PC. A cable TK812 is also needed.	3BSE038407R1

## 5.1.2 S800 I/O modules

### 5.1.2.1 Analog input modules

Name	Short Description	Article No.
AI810	Analog Input, 1x8 channels  0(4)..20 mA, 0...10 V, 12 bit, single ended, 0.1%, Rated isolation 50 V. Use Module Termination Unit TU810, TU812, TU814, TU830, TU833, TU835, TU838.	3BSE008516R1
AI815	Analog Input, 1x8 channels, HART  0(4)..20mA, 0(1)..5V, 12bit, single ended, 0.1%, Rated isolation 50V. Current limited transmitter power distribution. Use Module Termination Unit TU810, TU812, TU814, TU830, TU833, TU835 or TU838.	3BSE052604R1
AI820	Analog Input, 4x1 channel  +-20 mA, 0(4)..20 mA, +-10 V, +-5 V, 0(1)..5 V, diff., 5 0V CMV, 14 bit +sign. Rin(curr)250 Ohm, Rated isolation 50 V. Use Module Termination Unit TU810, TU812, TU814, TU830, TU833.	3BSE008544R1
AI825	Analog Input, 4x1 channel, galvanically isolated  -20..20 mA, 0(4)..20 mA, -10...10 V, 0(2)...10 V, Galvanically isolated channels. 14 bit+sign, 0.1%, Rated isolation 250 V. Use Module Termination Unit TU811, TU813, TU831.	3BSE036456R1
AI830A	Analog Input, 1x8 channels RTD  Pt100, Ni100/120, Cu10, R, Rated isolation 50 V. Use Module Termination Unit TU810, TU812, TU814, TU830, TU833.	3BSE040662R1
AI835A	Analog Input, 8 channels, Thermocouple / mV  Rated isolation 50 V. Use Module Termination Unit TU810, TU812, TU814, TU830, TU833.	3BSE051306R1
AI843	Analog Input, Redundant or Single 1x8 channels Thermocouple / mV  Rated isolation 50 V. Use Modules Termination Unit TU830, TU833, TU842, TU843.	3BSE028925R1

Name	Short Description	Article No.
AI845	Analog Input, redundant or single, 1x8 channels HART 0(4)...20 mA, 0(1)...5 V, 12 bit, single ended, 0.1%, Rated isolation 50 V. Current limited transmitter power distribution. Advanced on-board diagnostics. Use Module Termination Unit TU810, TU812, TU814, TU830, TU833, TU835, TU838, TU844, TU845.	3BSE023675R1
AI890	Analog Input, 1x8 channels with Intrinsic Safety Interface (4)..20 mA single ended 0,1%. Rated isolation 50 V. Use Module Termination Unit TU890 or TU891.	3BSC690071R1
AI893	Analog Input 8 channels, temperature measuring. Intrinsic Safety Interface, G3 compliant  For TC and RTD sensors. Rated isolation 50 V. Protection class G3. Use Module Termination Unit TU890 or TU891.	3BSC690141R1
AI895	Analog Input, 1x8 channels with Intrinsic Safety and HART, G3 compliant.  4..20 mA single ended 0,1%. Rated isolation 50 V. Protection class G3. Use Module Termination Unit TU890 or TU891.	3BSC690086R1

## 5.1.2.2 Analog output modules

Name	Short Description	Article No.
AO810V2	Analog Output, 1x8 channels, 0(4)..20 mA  0(4)..20 mA, 14 bit RLmax 500/850 Ohm, Rated isolation 50 V. Use module Termination Unit TU810, TU812, TU814, TU830 or TU833.	3BSE038415R1
AO815	Analog Output, 1x8 channels, HART  4..20mA, 12bit, 0.1%, RLmax 750 ohm, Rated isol. 50V. Use Module Termination Unit TU810, TU812, TU814, TU830 or TU833.	3BSE052605R1
AO820	Analog Output, 4x1 channel  +-20 mA, 0(4)..20 mA, +-10 V, 12 bit+sign. Indiv. isolation channels. RL max 500 Ohm, Rated isolation 50 V. Use Module Termination Unit TU810, TU812, TU814, TU830, TU833.	3BSE008546R1
AO845A	Analog Output, redundant or single, 1x8 channels, HART  4...20 mA, 12 bit, 0.1%, RLmax 750 ohm, Rated isolation 50 V. Advanced on-board diagnostics. Use Module Termination Unit TU810, TU812, TU814, TU830, TU833, TU842, TU843.	3BSE045584R1
AO890	Analog Output, 1x8 channels with Intrinsic Safety Interface  0 (4)..20 mA 0,1%. RL max 750 Ohm Rated isolation 50 V. Use Module Termination Unit TU890 or TU891.	3BSC690072R1
AO895	Analog Output 1x8 channels with Intrinsic Safety and HART. G3 compliant  4..20 mA 0,1%. RL max 750 Ohm Rated isolation 50 V. Protection class G3. Use Module Termination Unit TU890 or TU891.	3BSC690087R1

### 5.1.2.3 Digital input modules

Name	Short Description	Article No.
DI810	Digital Input, 24 VDC, 2x8 channels  Rated isolation 50 V. Use Module Termination Unit TU810, TU812, TU814, TU830, TU833, TU838.	3BSE008508R1
DI811	Digital Input, 48 VDC, 2x8 channels  Rated isolation 50 V. Use Module Termination Unit TU810, TU812, TU814, TU830, TU833, TU838.	3BSE008552R1
DI814	Digital Input, 24 VDC, 2x8 channels  Rated isolation 50 V. Use Module Termination Unit TU810, TU812, TU814, TU830, TU833, TU838.	3BUR001454R1
DI820	Digital Input, 120 VAC, 8x1 channel  Rated isolation 250 V. Use Module Termination Unit TU811, TU813, TU831.	3BSE008512R1
DI821	Digital Input, 230 VAC, 8x1 channel  Rated isolation 250 V. Use Module Termination Unit TU811, TU813, TU831.	3BSE008550R1
DI825	Digital Input, 125 VDC SOE, 1x8 channels  Individually Isolated channels, Rated isolation 250 V. Supports Sequence of Events (SOE). Use Module Termination Unit TU811, TU813, TU831.	3BSE036373R1
DI830	Digital Input, 24 VDC SOE, 2x8 channels  Rated isolation 50 V. Supports Sequence of Events (SOE). Use Module Termination Unit TU810, TU812, TU814, TU830, TU833, TU838.	3BSE013210R1
DI831	Digital Input, 48 VDC SOE, 2x8 channels  Rated isolation 50 V. Supports Sequence of Events (SOE). Use Module Termination Unit TU810, TU812, TU814, TU830, TU833, TU838.	3BSE013212R1
DI840	Digital Input, redundant or single, 24 VDC, 1x16 channels  Advanced On-Board diagnostics. Rated isolation 50 V. Use Module Termination Unit TU810, TU812, TU814, TU830, TU833, TU838, TU842, TU843.	3BSE020836R1
DI885	Digital Input, 24 / 48 VDC SOE, 1x8 channels  Rated isolation 50 V. Supports Sequence of Events (SOE). Use Module Termination Unit TU810, TU812, TU814, TU830, TU833.	3BSE013088R1
DI890	Digital Input, 8x1 channel with Intrinsic Safety Interface  Rated isolation 50 V. Use Module Termination Unit TU890 or TU891.	3BSC690073R1



## 5.1.2.4 Digital output modules

Name	Short Description	Article No.
DO810	Digital Output, 24 VDC, 2x8 channels 0.5 A, Short circuit proof, Rated isolation 50 V. Use Module Termination Unit TU810, TU812, TU814, TU830, TU833.	3BSE008510R1
DO814	Digital Output, current sinking, 2x8 channels 0,5 A, shortcut circuit proof, Rated isolation 50 V. Use Module Termination Unit TU810, TU812, TU814, TU830, TU833, TU838.	3BUR001455R1
DO815	Digital Output, 24 VDC, 2x4 channels 2.0 A short circuit proof. Rated isolation 50 V. Use Module Termination Unit TU810, TU812, TU814, TU830, TU833.	3BSE013258R1
DO820	Digital Output, Relay, normal open, 8x1 channel 24-230 VAC 3 A, cos phi>0.4, d.c. 42 W, Rated isolation 250 V. Use Module Termination Unit TU811, TU813, TU831, TU836, TU837.	3BSE008514R1
DO821	Digital Output, Relay, normal closed, 8x1 channel 24-230 VAC 3 A, cos phi>0.4, d.c. 42 W, Rated isolation 250 V. Use Module Termination Unit TU811, TU813, TU831, TU836, TU837.	3BSE013250R1
DO840	Digital Output, redundant or single, 2x8 channels 24 VDC, 0.5 A. Advanced On-board diagnostics. Rated isolation 50 V. Use Module Termination Unit TU810, TU812, TU814, TU830, TU833, TU842, TU843.	3BSE020838R1
DO890	Digital Output, 4x1 channel with Intrinsic Safety Interface Rated isolation 50 V. Use Module Termination Unit TU890 or TU891.	3BSC690074R1

## 5.1.2.5 Pulse counting modules

Name	Short Description	Article No.
DP820	Pulse Counter RS-422, Current, 5 V, (12 V), 24 V  2 channels bidirectional pulse counters and frequency measurement. 1,5 MHz Rated isolation 50 V. Use Module Termination Unit TU810, TU812, TU814, TU830, TU833.	3BSE013228R1
DP840	Pulse Counter or Frequency Measurement Module, redundant or single, 1x8 channels  20 kHz. Rated isolation 50 V. Use Module Termination Unit TU810, TU812, TU814, TU830, TU833, TU842, TU843, TU844, TU845.	3BSE028926R1

## 5.1.2.6 Label sets for I/O modules

Name	Short Description	Article No.
Extra, Front label set	I/O-box 16 channels  Sheet with 12 labels for 16 channels I/O modules.	3BSC970087R1
Extra, Front label set	I/O-box 8 channels  Sheet with 12 labels for 8 channels I/O modules.	3BSC970088R1
Label set	I/O-box 4 channels  Sheet with 12 labels for 4 channel I/O modules.	3BSC970306R1

## 5.1.2.7 Module termination units

Name	Short Description	Article No.
TU805K01	Termination Units  Termination Units for two or three wire connection of DI801 and DO801. Include 10 pcs of Termination Unit TU805.	3BSE035990R1
TU810V1	Compact Module Termination Unit 50 V  2x8 signal terminals, rated isolation 50 V.	3BSE013230R1
TU811V1	Compact Module Termination Unit 250 V  1x8 signal terminals rated isolation 250 V.	3BSE013231R1
TU812V1	Compact Module Termination Unit 50 V  With 25 pin D-sub connector, rated isolation 50 V. D-sub (female) connector is not enclosed.	3BSE013232R1
TU813	Compact Module Termination Unit 250 V  2x8 Signal terminals, Rated isolation 250 V. Detachable (pluggable) connectors are enclosed.	3BSE036714R1
TU814V1	Compact Module Termination Unit 50 V  2x8 Signal terminals, rated isolation 50 V. Detachable (pluggable) connectors are enclosed.	3BSE013233R1
TU830V1	Extended Module Termination Unit 50 V  2x16 signal terminals rated isolation 50 V.	3BSE013234R1
TU831V1	Extended Module Termination Unit 250 V  2x8 signal terminals rated isolation 250 V.	3BSE013235R1
TU833	Extended Module Termination Unit 50 V  2x16 signal terminals, Rated isolation 50 V. Spring-cage terminals.	3BSE038726R1
TU834	Extended Module Termination Unit 50 V  Used with AI880 / AI880A. Rated isolation 50 V. Shunt Stick not included.	3BSE040364R1
TU835V1	Extended Module Termination Unit 50 V  8 fused power outlets, 8 signal terminals, rated isolation 50 V	3BSE013236R1
TU836V1	Extended Module Termination Unit 250 V  2x4 fused signals, 2x4 return terminals, 2x2 L terminals, 2x2 N terminals. Rated isolation 250 V.	3BSE013237R1
TU837V1	Extended Module Termination Unit 250 V  8x1 fused isolated signals, 8x1 L terminals, 2x6 N terminals. Rated isolation 250 V.	3BSE013238R1

Name	Short Description	Article No.
TU838	Extended Module Termination Unit 50 V 2x4 fused transducer power outlets, 16 signal terminals, 2x4 return terminals, 2x2 L+, 2x2 L- terminals, rated isolation 50 V. Module is mounted horizontally.	3BSE008572R1
TU839	Extended Module Termination Unit 250 V 2x8 signal terminals. 2x4 fused sensor power. Rated isolation 250 V.	3BSE046966R1
TU842	Module Termination Unit, for redundant applications 50 V Used for AO845, DI840, DO840. Horizontal mounted DIN rail. Rated isolation 50 V.	3BSE020850R1
TU843	Module Termination Unit, for redundant applications 50 V. Used for AO845, DI840, DO840. Vertical mounted DIN rail. Rated isolation 50 V.	3BSE021443R1
TU844	Module Termination Unit, for redundant applications 50 V Used with AI845, AI880 and DP840. Horizontal mounted DIN rail. Rated isolation 50 V. Shunt Stick not included.	3BSE021445R1
TU845	Module Termination Unit, for redundant applications 50 V Used with AI845, AI880A and DP840. Vertical mounted DIN rail. Rated isolation 50 V. Shunt Stick not included.	3BSE021447R1
TU850	Extended Module Termination Unit 50 V 2x8 signal terminals and 2x8 disconnectable current limited sensor / transmitter outlet power terminals. Rated isolation 50 V.	3BSE050930R1
TU890	Module Termination Unit for Intrinsic Safety applications 3x9 signal terminals Rated isolation 50 V. Including wiring separator.	3BSC690075R1
TU891Z	Module Termination Unit for non Intrinsic Safety applications, G3 Compliant 3x9 signal terminals Rated isolation 50 V.	3BSC840220R1
TY801K01	8x Shunt Stick TY801 125 + 125 Ohm shunt. Used for AI845 and AI880 on TU844, TU845	3BSE023607R1
TY804K01	8x Shunt Stick TY804 1000 Ohm shunt. Used for DP840 on TU844, TU845.	3BSE033670R1



## 5.1.3 S800L modules

### 5.1.3.1 Analog input modules

Name	Short Description	Article No.
AI801	Analog Input, 1x8 channels 0(4)..20 mA, 12 bit, single ended, 0.1%, Rated isolation 50 V.	3BSE020512R1

### 5.1.3.2 Analog output modules

Name	Short Description	Article No.
AO801	Analog Output, 1x8 channels 0(4)..20 mA, 12 bit, RLmax 850 Ohm, Rated isolation 50 V.	3BSE020514R1

### 5.1.3.3 Digital input modules

Name	Short Description	Article No.
DI801	Digital Input, 24 VDC, 1x16 channels Rated isolation 50 V.	3BSE020508R1
DI802	Digital Input, 120 VAC / DC, 8x1 channel Rated isolation 250 V.	3BSE022360R1
DI803	Digital Input, 230 VAC / DC, 8x1 channel Rated isolation 250 V.	3BSE022362R1

### 5.1.3.4 Digital output modules

Name	Short Description	Article No.
DO801	Digital Output, 24 VDC, 16 channels 0.5 A. Short circuit proof, Rated isolation 50 V.	3BSE020510R1
DO802	Digital Output, Relay, normal open, 8x1 channel 24-230 V, AC Rated isolation 250 V.	3BSE022364R1

### 5.1.3.5 Label sets for S800L I/O modules

Name	Short Description	Article No.
Label Set S800L	16 channels Sheet with 12 labels for 16 channels I/O modules.	3BSE019419R1
Label Set S800L	8 channels Sheet with 12 labels for 8 channels I/O modules.	3BSE019419R2

## 5.1.4 ModuleBus communication parts

Name	Short Description	Article No.
TB805	Bus Outlet  ModuleBus extension cable adaptor D-sub 25, female. One required per extension cable TK801.	3BSE008534R1
TB845	Dual ModuleBus outlet  ModuleBus extension cable adaptor two D-sub, female. Two TK801 cables for redundancy.	3BSE021437R1
TB806	Bus Inlet  ModuleBus extension cable adaptor D-sub 25, male. One required per extension cable TK801.	3BSE008536R1
TB846	Dual ModuleBus inlet  ModuleBus extension cable adaptor two D-sub, male. Two TK801 cables for redundancy.	3BSE021439R1
TK801V003	TK801V003 Cable  ModuleBus Extension Shielded Cable 0.3m D-sub 25, male-female. G3 compliant.	3BSC950089R1
TK801V006	TK801V006 Cable  ModuleBus Extension Shielded Cable 0.6m D-sub 25, male-female. G3 compliant.	3BSC950089R2
TK801V012	TK801V012 Cable  ModuleBus Extension Shielded Cable 1.2m D-sub 25, male-female. G3 compliant.	3BSC950089R3
TB807	ModuleBus terminator  G3 compliant.	3BSE008538R1
TB820V2	ModuleBus Cluster Modem  Optical cluster modem for non redundant operation. Including: 1x Power Supply Connector 1x TB807 ModuleBus Terminator.	3BSE013208R1
TB825	Optical Media Converter  Short to long distance optical fiber conversion. For ModuleBus communication up to 1000 m.	3BSE036634R1
TB840A	ModuleBus Cluster Modem  Optical cluster modem for 1+1 redundant operation.	3BSE037760R1
TB810	ModuleBus Optical Port  Used together with CI810, CI820, CI830. Use with S800 I/O and ABB Drives (10 Mbits driver)	3BSE008560R1

Name	Short Description	Article No.
TB811	ModuleBus Optical Port  Used together with CI810, CI820, CI830. Used with ABB Drives equipment. (5 Mbits driver).	3BSE008568R1
TB842	ModuleBus Optical Port  Used together with CI801 and CI840, connected via TB806 or TB846. 10 Mbits driver.	3BSE022464R1
TU807	Termination Unit for TB840 / TB840A  Support for single ModuleBus I/O. Including: 1x TB807.	3BSE039025R1
TU840	Termination Unit for 1+1 TB840, support for redundant I/O  Including: 1x Power Supply Connector 2x TB807 ModuleBus Terminator.	3BSE020846R1
TU841	Termination unit for 1+1 TB840, support for non- redundant I/O  Including: 1x Power Supply Connector 1x TB807 ModuleBus Terminator.	3BSE020848R1
TU848	MTU with individual power supply for redundant TB840 / TB840A  Support for dual ModuleBus. Including: 2x TB807.	3BSE042558R1
TU849	MTU with individual power supply for redundant TB840 / TB840A  Support for single ModuleBus. Including: 1x TB807.	3BSE042560R1
TK811V015	POF Cable, 1.5 m, Duplex  L = 1.5 m latching duplex connector Duplex plastic fibre.	3BSC950107R1
TK811V050	POF Cable, 5 m, Duplex  L = 5 m latching duplex connector Duplex plastic fibre.	3BSC950107R2
TK811V150	POF Cable, 15 m, Duplex  L = 15 m latching duplex connector Duplex plastic fibre.	3BSC950107R3
TK812V015	POF Cable, 1.5 m, Simplex  L = 1.5 m latching connector Simplex plastic fibre.	3BSC950118R1
TK812V050	POF Cable, 5 m, Simplex  L = 5.0 m latching connector Simplex plastic fibre.	3BSC950118R2
TK812V150	POF Cable, 15 m, Simplex  L = 15 m latching connector Simplex plastic fibre.	3BSC950118R3



## 5.1.5 Power supplies

Name	Short Description	Article No.
SD821	Power Supply Device  Input 115 / 230 VAC, switch selectable, output 24 VDC, 2.5 A. If redundant power application is required connect to SS82x Voting Unit. Width = 50 mm. DIN rail mounted.	3BSC610037R1
SD822	Power Supply Device  Input 115 / 230 VAC, switch selectable, output 24 VDC, 5 A. If redundant power application is required connect to SS82x Voting Unit. Width = 65 mm. DIN rail mounted.	3BSC610038R1
SD823	Power Supply Device  Input 115 / 230 VAC, switch selectable, output 24 VDC, 10 A. If redundant power application is required connect to SS82x Voting Unit. Width = 120 mm. DIN rail mounted.	3BSC610039R1
SS822	Power Voting Unit  With dual 24 VDC 20 A inputs, single 24 VDC, 20 A output. Each power input supervised. Used if redundant power supply is required. For use with SD821 / 822 / 823. Width=50 mm. DIN rail mounted.	3BSC610042R1
SD831	Power Supply Device  Input 100-240 VAC or 110-300 VDC. Output 24 VDC, 3 A. If redundant power application is required connect to SS8XX Voting unit. Width = 35 mm. DIN rail mounted.	3BSC610064R1
SD832	Power Supply Device  Input 100-120 / 200-240 VAC. Output 24 VDC, 5 A, auto-select input. If redundant power application is required connect to SD8XX Voting unit. Width = 35 mm. DIN rail mounted.	3BSC610065R1
SD833	Power Supply Device  Input 100-120 / 200-240 VAC, auto-select input. Output 24 VDC, 10 A. If redundant power application is required connect to SD8XX Voting unit. Width = 60 mm. DIN rail mounted.	3BSC610066R1
SD834	Power Supply Device  Input 100-240 VAC or 110-300 VDC. Output 24 VDC, 20 A. If redundant power application is required connect to SS8XX Voting unit. Width = 85 mm. DIN rail mounted.	3BSC610067R1
SS832	Voting Device  Input 24 VDC. Dual 24 V to single 24 V, 2x 10 A. Width = 35 mm. DIN rail mounted.	3BSC610068R1

## 5.1.6 User documentation

Name	Short Description	Article No.
S800 I/O	General Information and Installation User's Guide.	3BSE020923R5001
S800 I/O	Modules and Termination Units User's Guide.	3BSE020924R5011
S800 I/O	Fieldbus Communication Interface for AF100 User's Guide.	3BSE020925R301
S800 I/O	Fieldbus Communication Interface for PROFIBUS DP / DP-V1 User's Guide.	3BSE020926R5001
S800 I/O	Modules and Termination Units with Intrinsic Safety Inter- face User's Guide.	3BSE020927R4001
S800 I/O	Advant Fieldbus 100 User's Guide.	3BSE000506R801
S800 I/O	PROFIBUS FCI - Memory maps for CI830 Reference Manual.	3BSE019081R501
S800 I/O	PROFIBUS FCI - Memory maps for CI840 Reference Manual.	3BSE025251R5001
S800 I/O	PROFIBUS FCI - Memory maps for CI801 Reference Manual.	3BSE036959R5001

## 5.2 S900 Remote I/O

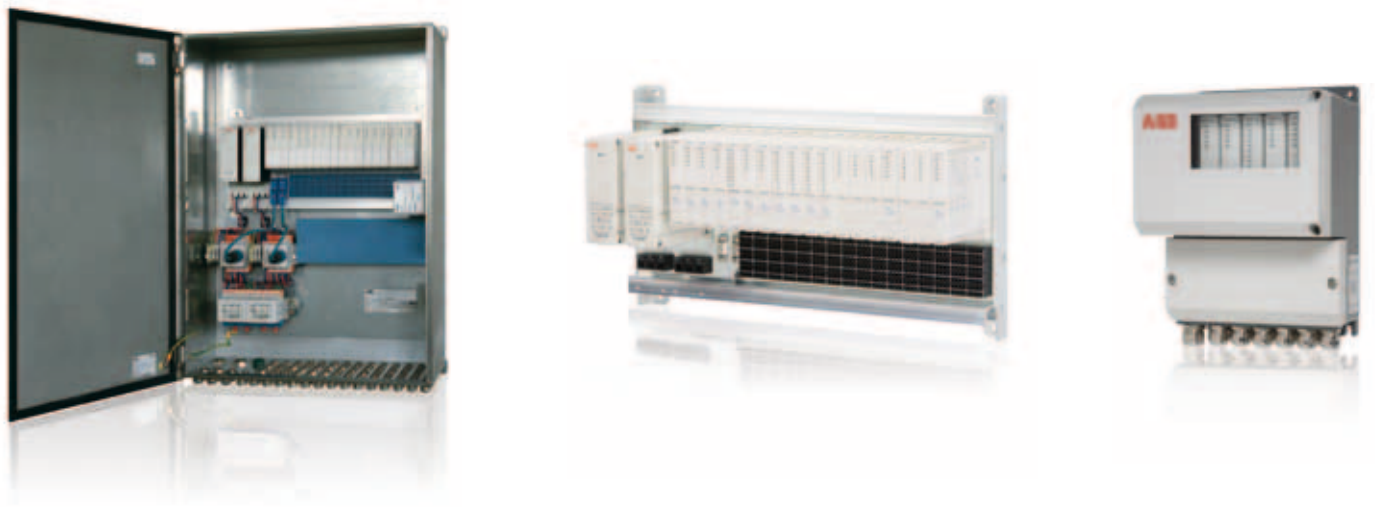

### System description of S900 Remote I/O system

S900 provides the input and output modules needed for intrinsically safe field signal connection. The field signals are digitized in every S900 functional module, electrically isolated, and then output via an internal serial bus. The communication interface converts the signals to adapt them to the standardized PROFIBUS-DP V1 fieldbus protocol.

Supervisory process control systems, DCS or SCADA systems use an intrinsically safe fieldbus to communicate with the communication interface. A Profibus connect allows the configuration of the individual S900 stations with cyclic data exchange, acyclic services and communication with HART-compatible field instruments. All functional modules can be replaced easily and quickly, which is an advantage especially in the installation or maintenance phase in hazardous area. The functional modules and the – optionally redundant – communication interface modules placed in Zone 1 can be removed and plugged in while operation is running.

Integrated encapsulated switch-off mechanisms allow for hot swapping of the power supplies. Due to its little space requirements and robust design and its environmentally ruggedized case, the S900 Remote I/O System is a cost-saving solution for use on site, in hazardous Zone 1 or Zone 2 areas (ATEX).

#### Various installation solutions for different tasks

The S900 components are arranged in a passive termination unit for direct mounting in a junction box. The termination unit contains the internal redundant communication interface and all connectors for the field circuitry, communication and primary power. The functional modules are plugged in the appropriate slot of the termination unit.

Two termination unit versions are available: a redundant one with slots for two power supplies and two communication interfaces and 16 slots for the different functional modules (type TU921), and a nonredundant one (integrated in a field housing type CB220) with a maximum of 4 slots. Digital functional modules are designed for up to 8 channels, and analog functional modules for up to 4 channels. Thus, up to 128 digital or up to 64 analog channels are possible for each fieldbus node when using a redundant termination unit. It is also possible to combine different functional modules. Up to 125 fieldbus nodes can be connected to a single fieldbus network. This means that up to 10,000 inputs or outputs can be handled by single S900 network. Extensions beyond this scope depend upon the fieldbus type used.

#### No external signal adaptation or routing required

S900 provides various input and output modules: Analog input modules with or without integral transmitter supply, or with direct temperature measuring input for 2-, 3- or 4-wire resistance thermometers or thermocouples with internal cold junction compensation. Analog output modules for direct positioner or actuator control. Solenoid driver units or NAMUR inputs for intrinsically safe and short-circuit-proof power supply of digital field instruments.

Additionally, options are available for critical applications, allowing for channel-wise electrical isolation of the inputs and outputs. S900 permits direct connection of the entire field level through only 2 lines. As no separate routing, power supply or fusing is needed, the installation cost is reduced considerably.

## Consistent configuration

Just like local I/O modules, the individual S900 Remote I/O stations can be configured directly, using the engineering tool integrated in the Distributed Control System (DCS). The Device Type Manager (DTM) exactly “knows” the functionality and parameters of the individual functional modules and their interface to the bus. Besides the module configuration, the DTM also provides for forcing (simulation) of the inputs and outputs and for display of the diagnosis messages.

Due to the standardized FDT / DTM interface the DTM can be easily integrated in the configuration tool of the DCS. Since the DTM belongs to the instrument and not to the DCS, the user has to get familiar with the operating procedure only once. The complete configuration and all parameters are automatically loaded into the S900 stations when the bus network is starting up or upon replacement of a hardware component. So, this is a real “plug & play” system.

In consequence, there is no local service interface for the communication interface, since it is no longer needed. The configuration and parameter data is exclusively visualized and updated by the DTM. The data is stored in the central database of the engineering tool. Thus, system-wide data consistency is ensured. The efforts needed for commissioning and trouble-shooting are reduced to the minimum. Of course, it is alternatively possible to use the GSD file for commissioning/putting into operation.

## System features of S900 Remote I/O system

S900 is a remote I/O system for use in hazardous areas. It provides bus-compatible local inputs and outputs (protection class IP20) for connection of digital and analog field instruments. Due to its degree of explosion protection it can be mounted in both hazardous areas (zone 1 and zone 2 / ATEX) and safe areas.

The system consists of a termination unit accommodating the power supply units, the communication interfaces, and the I/O modules.

The passive termination unit ensures power distribution and data transfer, and also provides the connection platform.

The power supply units reliably power the entire system. One power supply unit is sufficient for normal operation. A second (redundant) power supply unit can be added, to improve the system availability (for termination unit TU921).

The communication interface controls all data traffic between the I/O modules and the distributed control system (DCS) or the programmable logical controller (PLC). The communication interfaces can also be used in redundancy mode (line redundancy and station redundancy with termination unit TU921).

The termination unit is accommodated in a suitable field housing (junction box) to protect it from environmental exposure. When mounting the unit in a hazardous area you have to use a field housing with increased safety (EEx-e). Appropriate ready-made S900 field housings are available.

The S900 Remote I/O System is powered / connected via sufficiently protected terminals on the termination unit, with increased safety EEx-e. The power supply units, the communication interfaces, and the I/O modules are plugged into the termination unit and locked automatically. The power supply modules have a built-in shut-off mechanism with automatic locking and can be plugged / removed under power (even in zone 1 / ATEX), although the EEx-e supply in the primary circuit is still active in this case. As a result, the S900 Remote I/O system does not require a flame-proof enclosure or pressurized housing and, therefore, is easy to handle.

The termination unit and the power supply unit(s) ensure intrinsically safe power supply of the communication interfaces and up to 16 I/O modules. The mounting termination unit provides all internal connections. Thus, only the peripheral units need to be connected by the user. Also, hot swapping of the communication interfaces and I/O modules is possible, i.e. these units can be connected or removed during operation. This ensures easy replaceability of all active components, and a high degree of flexibility and user-friendliness.

Field instruments complying with protection class EEx ia IIC can be connected to the Ex I/O modules. Up to 16 I/O modules can be run on the same termination unit. Each I/O module is designed for connecting 2, 4, 6 or 8 field instruments, depending on the respective model. The I/O modules and the underlying field instrument level are powered via the termination unit. All intrinsically safe modules are self-feeding and short-circuit proof. No separate routing level with additional power supply and individual fusing is required.

HART communication in the field with all analog S900 I/O modules is possible via a PC or a hand-held terminal. In addition, the special HART variants allow for a consistent HART communication up to the distributed control system (DCS). Cyclic transmission of all secondary HART variables, HART diagnosis, and (acyclic) configuration of all HART devices are possible.

The S900 I/O modules are slot-addressed and, therefore, do not require any settings on the modules themselves. The PROFIBUS address is set via three coding switches on TU921 and two coding switches on CB220. The S900 communication interface, the I/O modules, and the connected HART devices are configured and parameterized via a fieldbus network. No additional configuration and parameterization network is required. The communication interface and the I/O modules have built-in LEDs allowing for „on site“ diagnostics. All diagnostic and status indicator LEDs comply with DIN EN 60073 and NAMUR NE44. In addition, PROFIBUS diagnosis down to channelspecific error messages is possible via the communication bus.

## Required S900 components

The S900 Remote I/O System for hazardous areas in its minimum hardware configuration (based on termination unit TU921S) consists of the following components:

Type TU921S/B/N	Extended Termination Unit / TU16R-Ex
Type SA920S/B/N	Power Supply 24 V DC
Type CI920S/B/N	Communication Interface / CIPB-Ex
Type BP910S/B	Sub D connector EEx i for PROFIBUS-DP
Type DX910S/B/N	Digital I/O Module / DIO-Ex
Type BI9xxS/B/N	Fieldbus isolating repeater / (see ordering information for accessories)

If required, a 230 VAC / 24 VDC power supply unit must be provided by the customer to ensure 24 VDC supply of the S900 Remote I/O System.

For use of 230 VAC / 24 VDC power supplies outside of hazardous area the power supply SD823 of the S800 I/O system can be used.

For use of 230 VAC / 24 VDC power supplies in hazardous area the power supplies series QUINT of Phoenix supplier can be used. For more information see the S900 remote I/O installation guide.

For more installation details refer to the installation guide on the CD910 (Catalog No. 3KDE175839L9100). The CD910 will be delivered with every ordered TU921 or CB220.

## Requirements on PLC/DCS master systems

S900 Remote I/O can be connected to systems with a PROFIBUS DP master.

The PROFIBUS-DP V0 services provide the following S900 Remote I/O functions:

- Configuring / setting parameters of the S900 Remote I/O station by restarting all slaves.
- S900 diagnosis messages
- Reading HART secondary variables from the connected field instruments
- Reading HART diagnosis from the connected field instruments through PROFIBUS diagnosis messages.

To be able to use the full range of functions provided by the S900 Remote I/O System, the master has to support additional functions. Modern, state of the art master systems support PROFIBUS-DP V1 services, and are capable to (re)load user-defined and configuration parameters while the system is running, without affecting other slaves or requiring to restart the network.

PROFIBUS-DP V1 services allow you to

- simulate (force) the S900 inputs and outputs
- configure HART field instruments connected to the system

You can select special user-defined and configuration parameters and (re)load them while the system is running to

- change the parameters of the communication interfaces or of individual I/O modules
- add more S900 Remote I/O groups
- add, remove or replace S 900 I/O modules .

All I/O modules not involved in these parameter or configuration changes continue cyclic communication. The S900 outputs hold their values / states while the master is downloading the parameters.

Modern master systems meeting the requirements stated above are, for example

- System 800xA
- Melody / AC870P
- Freelance 800F
- other systems

## Number of PROFIBUS nodes

With PROFIBUS-DP a maximum of 32 nodes (including the master and the class 2 configuration tool, if applicable) can be connected to a segment. A maximum of 10 nodes per segment can be connected to the intrinsically safe PROFIBUS-DP. When using repeaters, you can connect up to 126 nodes to a DP master.

The specified transmission rate and the max. permissible cable length of the segments (see installation guide) must be observed. For example, a cable length of 400 m (1314 ft) is permissible for a network with a transmission rate of 500 kbauds. Longer cables are possible when using FO cables.

## I/O module power supply

The S900 power supplies are designed for two communication interfaces and up to 16 I/O modules of any type. No system limitations result from the selection of typical combinations of the module types DX910, AI930, AI950 and DO910.

System limitations exist for following I/O-modules:

- For the module type DO910 an additional calculation is requested for use with power valves which support less than 1500 Ohm input impedance
- For the module types AO920 (or AI920 / AI921) an additional heat dissipation calculation is requested.

The total power is limited to 55 Watt.

When using redundant termination units (e.g. TU921), a redundant slot can be left free for the power supply unit if required. The power supply units are designed to power the entire S900 station.

## Number of I/O modules

In accordance with the PROFIBUS standard up to 240 user parameters are available for parameterizing the S900 System. The S900 System uses one byte per module in Mode 1, and six bytes per module in Mode 2 for the module parameterization. The 16 slots can be assigned as required.

The total quantity of I/O data must not exceed 216 bytes. If no HART variables are to be transmitted, no system limitations result from this, since the max. possible I/O data quantity is 128 bytes, with up to 8 bytes per module and a maximum of 16 modules. Thus, an S900 Remote I/O Station can be equipped with up to 16 I/O modules.

However, the max. number of transferable HART secondary variables is limited, since the maximum quantity of I/O data is 240 bytes. The max. number of HART variables can be derived from the table below. If the system is configured using a configuration tool based on the FDT/DTM technology, the DTM will monitor the system limits (see the DTM manual).

Modules	I/O Modules		HART Devices
	Out Bytes	In/Status Bytes	In Bytes
CI920 <sup>1</sup>	0	0	0
AI930 <sup>1</sup>	0	8	0/4/16/32 <sup>2</sup>
AO930 <sup>1</sup>	8	0	0/4/16/32 <sup>2</sup>
AI950 <sup>1</sup>	0	8	0
DX910 <sup>1</sup>	1	1	0
DI910 with Status <sup>1</sup>	1	2	0
DO910 <sup>1</sup>	1	0	0
DP910 <sup>1</sup>	2	8	0

I/O data of various I/O modules

1) stands for S900 S/B/N modules

2) 0...8 (0/4/16/32) HART variables per channel can be selected here

Calculation of the total I/O data example

Modules: 1 x CI920, 6 x AI930, 4 x AO930, 6 x DX910 with status

Total of out bytes =  $6 \times 0 + 4 \times 8 + 6 \times 1 = 38$

Total of in/status bytes =  $6 \times 8 + 4 \times 0 + 6 \times 2 = 60$

Total of I/O bytes =  $38 + 60 = 98$

Number of still available bytes =  $216 - 98 = 118$

Number of possible HART variables =  $118 / 4 = 29$

## Cycle time

The PROFIBUS master defines the transmission rate used in the system. The internal CAN-Bus cycle time is 5 ms for processing 128 digital signals and 20 ms for processing 64 analog signals. The response time of the entire system, consisting of controller and remote I/O, depends on the total I/O data quantity of all PROFIBUS nodes and the processing speed of the supervisory system. The S900 output data are synchronized with the PROFIBUS.

The following approximation formula is valid  $T_R = T_i + 2 \times T_B + T_S$

$T_R$  = response time

$T_i$  = internal cycle time

$T_B$  = cycle time of the higher-level bus

$T_S$  = cycle time of the DCS

With a bus cycle time of 5 ms and a DCS cycle time of 5 ms, a response time of

$T_R = 5 + 2 \times 5 + 5 = 20$  ms results from this for the 128 digital signals for typical application.

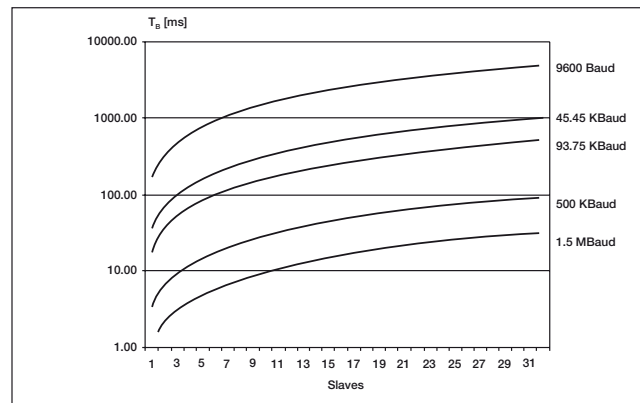

Figure 9: PROFIBUS DP cycle time

## Range of applications

The S900 Remote I/O System is tailored to applications in the field of process engineering. It provides a variety of functions which make the system robust, fault-tolerant and easy to diagnose. The main features of the system are its compact design, the redundant bus architecture, and the direct access to the configuration data of the connected HART-compatible instruments via the fieldbus network.

The S900 Remote I/O System is the economic extension of your sensors and actors which can be directly contacted via the standardized fieldbus protocol. Due to the FDT technology both simple digital field instruments or temperature sensors and the wellproven basis of the intelligent HART instruments can be integrated easily into the fieldbus system.

As a result, the S900 Remote I/O System provides a considerable cost-saving potential for all applications in the field of process engineering.

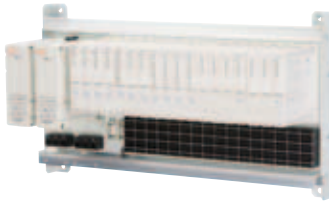

## Technical data of S900 Remote I/O system

### Device variants for:

Safe area mounting	Type N
Zone 2 mounting	Type B
Zone 1 mounting	Type S

Attention: Do not mix Type N, B, S components!

### General data of S900 Remote I/O system

#### Power supply

Material	Aluminium anodized
Colour	RAL 9002 + black
External dimensions (W x H x D)	47 x 129 x 117 mm
Weight	Approx. 1.5 kg

#### I/O modules and communication interface

Material	PC
Fire protection class	V2, UL 94 (DIN IEC 707)
Colour (light grey)	RAL 9002
External dimensions (W x H x D)	20 x 104 x 104 mm
Weight	Approx. 0.15 kg
Test voltage (fieldbus, PS, I/O)	1500 V
Test voltage (fieldbus -> I/O)	500 V (intrinsically safe Profibus)
Test voltage (I/O -> I/O)	500 V (with el. isolation)

#### Termination unit

Material	Aluminium chromatised
Colour	Aluminium + RAL 9002
External dimensions (W x H x D)	498 x 274 x 147 mm
Weight	Approx. 3 kg

#### Mounting

#### Zone1 / Zone 2 (modules B / S only)

Operating temperature	
horizontal mounting	-20 °C...60 °C
vertical mounting	not allowed
Storage temperature	-40 °C...85 °C

#### Standards

Transport / shock	15 g (IEC 68-2-27)
Function / Vibration	2 g (IEC 68-2-6)
Reference conditions	IEC 60770
EMC	EN 61326
Humidity	IEC 60654, T 1-4
Relative humidity	< 85% (annual average)
Condensation	Short duration, commissioning or temperature transient
Corrosive gases	ANSI/ISA S71.04 G3 Harsh Group A DIN EN 60068-2-60 Method 4



---

**System architecture of S900 Remote I/O system**

---

I/O modules per station	16 (on Termination Unit)
No. of channels	2, 4 and 8 channel

---

**S900 stations for Zone 1 (IS fieldbus via IS isolating repeater)**

---

Mounting options	Safe area, Zone 2, Zone 1
Stations / isolating repeater	Max. 10 stations type S

---

**S900 stations für Zone 2 (IS fieldbus via IS isolating repeater)**

---

Mounting options	Safe area, Zone 2
Stations / isolating repeater	Max. 10 stations type B

---

**S900 stations for safe area (standard fieldbus)**

---

Mounting options	Safe area
S900 stations per bus line	PROFIBUS non-Ex standard
Bus length (copper)	200 m (1.5 MBaud) 400 m (0.5 MBaud)
Bus length (fibre optic)	(see instruction manual)

---



## 5.2.1 Redundant termination unit TU921S/B/N

- Termination unit for up to 16 I/O modules
- Prepared for redundant system power and communication
- Up to 4 terminals per channel
- Preselection of fieldbus address
- Prepared for certified field housing
- Mounting in Zone 1 or Zone 2 possible

Name	Short Description	Article No.
TU921S	Redundant Termination Unit (TU16R-Ex)  For 16 I/O-modules. Redundant communication and power. (Delivery includes CD910).	3KDE175111L9210
TU921B	Redundant Termination Unit (TU16R-B)  For 16 I/O-modules. Redundant communication and power. (Delivery includes CD910).	3KDE175112L9210
TU921N	Redundant Termination Unit (TU16R)  For 16 I/O-modules. Redundant communication and power. (Delivery includes CD910).	3KDE175113L9210

## Technical data

### Technical data TU921S/B/N

#### Field Terminals

Rated supply voltage (PS)	Depending on power supply
System power terminals	Screw terminals
Wire CSA	0,5...2,5 mm <sup>2</sup>
Fieldbus plug connector	SUB D, 9 pins
Preselection of bus address	0...126 (rotary switch)
I/O Terminals (type TU921N)	Black
I/O Terminals (type TU921B)	EEx i (blue)
I/O Terminals (type TU921S)	EEx i (blue)
Wire CSA	0,5...2,5 mm <sup>2</sup>
Connection	Spring loaded

**Explosion protection (type ...S)** PTB 00 ATEX 2156 U  
II 2(1) G EEx e ib [ia] IIC

**Explosion protection (type ...B)** PTB 03 ATEX 2028  
II (2) G [EEx ib] IIB/IIC  
PTB 03 ATEX 2029  
II 3 G EEx nA II T4

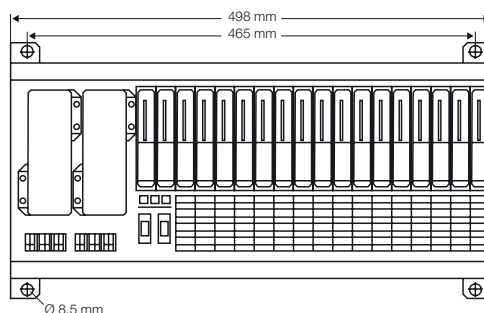
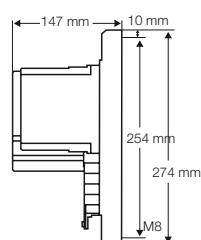



## 5.2.2 Power supply SA920S/B/N

- Powering of communication interfaces and I/O modules
- Hot swap capability (SA920S in Zone 1, SA920B in Zone 2)
- Redundant powering
- Alarm in case of power failure (with redundancy)
- Switching On by tighten the 4 switch-on interlock screws (only SA920B and SA920S)

Name	Short Description	Article No.
SA920S	Power Supply  For 24 VDC. The power supply filter type BP901S is not required. Do not mix SA910S with SA920S for redundancy (observe Release Notes).	3BDH000602R1
SA920B	Power Supply  For 24 VDC. The power supply filter type BP901S is not required. SA920B is the functional replacement for SA910B  do not mix SA910B with SA920B for redundancy (observe Release Notes).	3BDH000601R1
SA920N	Power Supply  For 24 VDC. The power supply filter type BP901S is not required. SA920N is the functional replacement for SA910N  do not mix SA910N with SA920N for redundancy (observe Release Notes).	3BDH000600R1

## Technical data

Technical data SA920S	
<b>Input</b>	
Power supply (PS)	24 VDC (19.2...32 VDC)
Max. current consumption	< 2.71 A / 24 V; < 3.39 A / 19.2 V
Total power loss	≤ 65 Watt, Ta ≤ 60 °C
<b>Output</b>	
Available power for modules	≤ 55 Watt, Ta ≤ 60 °C ≤ 45 Watt, Ta ≤ 70 °C
Number of powered modules (Ta ≤ 60 °C)	16 I/O modules + 2 x CI920S * < 16 I/O modules + 2 x CI920S ** e.g. 7 x DO910S + 2 x CI920S *** e.g. 12 x AO920S + 2 x CI920S
* for any I/O module with power loss < 2.5 W	
** for I/O modules with power loss > 2.5 W	
*** DO910S with power loss > 2.2 W (for valves < 1500 Ohm)	
<b>Explosion protection (type ...S)</b>	PTB 07 ATEX 2020
Type of protection	II 2 G Ex de [ib] IIC T4

## Technical data SA920B

### Input

Power supply (PS)	24 VDC (19.2...32 VDC)
Max. current consumption	< 2.71 A / 24 V; < 3.39 A / 19.2 V
Total power loss	≤ 65 Watt, Ta ≤ 60 °C

### Output

Available power for modules	≤ 55 Watt, Ta ≤ 60 °C ≤ 45 Watt, Ta ≤ 70 °C
Number of powered modules (Ta ≤ 60 °C)	16 I/O modules + 2 x CI920B * < 16 I/O modules + 2 x CI920B ** e.g. 7 x DO910B + 2 x CI920B *** e.g. 12 x AO920B + 2 x CI920B

\* for any I/O module with power loss < 2.5 W

\*\* for I/O modules with power loss > 2.5 W

\*\*\* DO910S with power loss > 2.2 W (for valves < 1500 Ohm)

### Explosion protection (type ...B)

Type of protection	PTB 03 ATEX 2028 II (2) G [EEx ib] IIB/IIC PTB 03 ATEX 2029 II 3 G EEx nA nC II T4
--------------------	---

## Technical data SA920N

### Input

Power supply (PS)	24 VDC (19.2...32 VDC)
Max. current consumption	< 2.95 A / 24 V; < 3.65 A / 19.2 V
Total power loss	≤ 70 Watt, Ta ≤ 60 °C

### Output

Available power for modules	≤ 60 Watt, Ta ≤ 60 °C ≤ 45 Watt, Ta ≤ 70 °C
Number of powered modules (Ta ≤ 60 °C)	16 I/O modules + 2 x CI920N * < 16 I/O modules + 2 x CI920N ** e.g. 9 x DO910N + 2 x CI920N ***

\* for any I/O module with power loss < 3.4 W

\*\* for I/O modules with power loss > 3.4 W

\*\*\* DO910N with power loss > 2.2 W (for valves < 1500 Ohm)



## 5.2.3 Communication interface CI920S/B/N

- Fieldbus protocol PROFIBUS-DP V1 (EN 50170)
- Coupling of the internal CAN bus to external PROFIBUS
- HART protocol on PROFIBUS-DP V1
- Line or media redundancy via two coupling modules
- Electrical isolation between field bus, power
- Diagnosis, configuration and parameterisation via PROFIBUS

Name	Short Description	Article No.
CI920S	Communication Interface V.1.5.x (CIPB-Ex)  Use only CI920S with the same firmware for redundancy for PROFIBUS DP-V1 (observe Release Notes)	3BDS014111
CI920B	Communication Interface V.1.5.x (CIPB-B)  Use only CI920B with the same firmware for redundancy for PROFIBUS DP-V1 (observe Release Notes).	3BDS014112
CI920N	Communication Interface V.1.5.x (CIPB)  Use only CI920N with the same firmware for redundancy for PROFIBUS DP-V1 (observe Release Notes).	3BDS014113

## Technical data

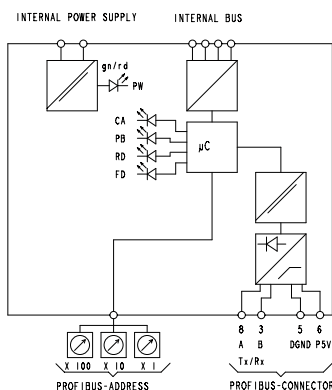

### Technical data CI920S/B/N

#### Fieldbus

	PROFIBUS DP-V1 limited to RS485 intrinsically safe (CI920S/B)
DP baud rate	Max. 1.5 Mbaud Hot Configuration in Run (HCIR)

#### Explosion protection (type ...S)

PTB 00 ATEX 2201  
II 2 G SYST EEx ib IIC T4

#### Explosion protection (type ...B)

PTB 03 ATEX 2028  
II (2) G [EEx ib] IIB/IIC  
PTB 03 ATEX 2029  
II 3 G EEx nA II T4

#### Via fieldbus

Station diagnosis  
Redundancy diagnosis  
I/O module diagnosis  
Channel diagnosis



## 5.2.4 Digital I/O modules DX910S/B/N

- Input for dry contacts or proximity switches (NAMUR)
- Output for low power intrinsically safe valves
- Short and break detection
- Electrical isolation between input / bus and input / power
- Common return for all inputs / outputs
- Configurable as a mixture of inputs and outputs
- 8 I/O channel, EEx ia II C

Name	Short Description	Article No.
DX910S	Digital Input or Output (DIO8-Ex)  Input for dry contact or NAMUR initiator. Output for low power intrinsic safe valves.	3KDE175311L9100
DX910B	Digital Input or Output (DIO8-B)  Input for dry contact or NAMUR initiator. Output for low power intrinsic safe valves.	3KDE175312L9100
DX910N	Digital Input or Output (DIO8)  Input for dry contact or NAMUR initiator. Output for low power valves.	3KDE175313L9100

## Technical data

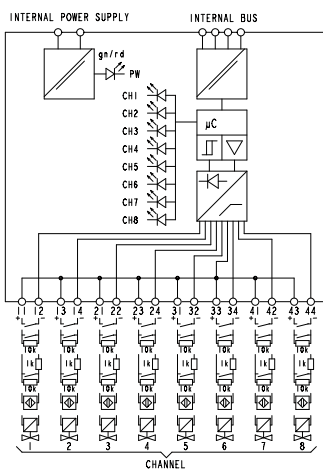

### Technical data DX910S/B/N

#### Input

No-load voltage	8 VDC
Short-circuit current	4 mA...5 mA
Switching point in range	1.4...1.8 mA
Switching hysteresis	0.2 mA
Switching frequency	< 100 Hz
Short-circuit detection	< 300...350 Ohm
Line-break detection	< 0.1...0.2 mA

#### Explosion protection (type ...S)

PTB 00 ATEX 2180  
II 2(1) G EEx ib [ia] IIC T4

#### Explosion protection (type ...B)

PTB 03 ATEX 2078  
II (1) G [EEx ia] IIB/IIC  
PTB 03 ATEX 2079  
II 3 G EEx nA II T4

#### Input or output

Max. short-circuit current	$I_o = 44 \text{ mA}$
Max. voltage	$U_o = 9.6 \text{ V}$
Max. power	$P_o = 106 \text{ mW}$
External inductance	$L_o = 1 \text{ mH}$
External capacitance	$C_o = 1100 \text{ nF}$



## 5.2.5 Solenoid driver DO910S/B/N

- Output for intrinsically safe valves or alarms
- Integrated driving power
- Short and break detection
- Electrical isolation between output / bus and output / power
- Electrical isolation channel to channel
- 4 channels, EEx ia II C

Name	Short Description	Article No.
DO910S	Digital Output (DO4-Ex) Output for intrinsic safe valves.	3KDE175321L9100
DO910B	Digital Output (DO4-B) Output for intrinsic safe valves.	3KDE175322L9100
DO910N	Digital Output (DO4) Output for valves.	3KDE175323L9100

## Technical data

### Technical data DO910S/B/N

#### Output

Supply voltage and current	21 V / 8 mA (Curve A) 18 V / 20 mA (Curve A) 15 V / 30 mA (Curve B) 12 V / 40 mA (Curve B)
No-load voltage	24 VDC (16 VDC)
Internal resistance	300 Ohm
Switching frequency	< 100 Hz
Line-break detection	< 0.2...1.2 mA

<b>Explosion protection (type ...S)</b>	PTB 01 ATEX 2048 II 2(1) G EEx ib [ia] IIC T4
---	--

<b>Explosion protection (type ...B)</b>	PTB 03 ATEX 2078 II (1) G [EEx ia] IIB/IIC PTB 03 ATEX 2079 II 3 G EEx nA II T4
---	--

Max. short-circuit current	$I_o = 100 \text{ mA}$
Max. voltage	$U_o = 27 \text{ V (18,9 V)}$
Max. power	$P_o = 675 \text{ mW}$
External inductance	$L_o = 0.5 \text{ mH}$
External capacitance	$C_o = 46 \text{ nF}$

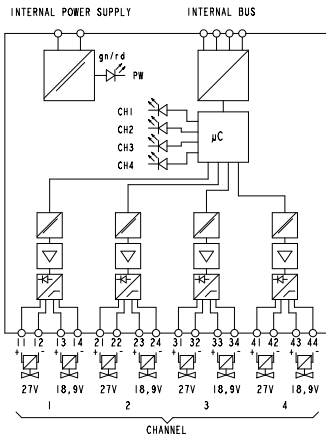



## 5.2.6 Relay output DO930N

- Relay output for higher switching power
- Output configurable as NO or NC contact
- Electrical isolation between output / bus and output / power
- Electrical isolation channel to channel
- Configurable as 4 x changeover contact
- Configurable as 6 x NO contact

Name	Short Description	Article No.
DO930N	Relay Output (RO6)	3BDS014114
With 4 normally-open contacts and 2 changeover contacts (only to use with CI920N Article No 3BDS014113).		

## Technical data

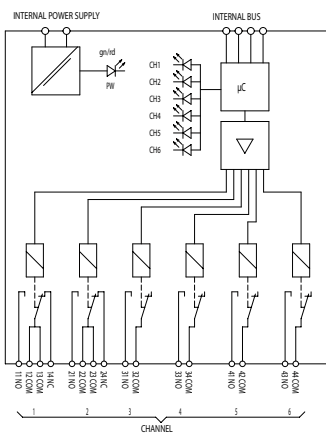

### Technical data DO930N

#### Output

Switching voltage	max. 60 VDC / 60 VAC min. 12 VDC / 12 VAC
Switching current	max. 1 A (60 VAC, 30 VDC) max. 0.7 A (60 VDC) min. 10 mA (DC) / 10 mA (AC)
Switching delay	> 4 ms... < 12 ms
Contact type	2 x changeover (channel 1 and 2) 4 x NO contacts (channel 3 to 6) The channels 3+4 and 5+6 resp. are switchable via software as changeover contacts. For this an external bridge is required at the terminals.
Mechanical life time	30 x 10 <sup>6</sup> switching cycles



## 5.2.7 Frequency input DP910S/B/N

- Frequency input for dry contacts or proximity switches
- Short and break detection
- Electrical isolation between input / bus and input / power
- Frequency measurement or counting applications
- 2 Function blocks
- Reset via fieldbus or control input
- Status outputs / Direction recognition

Name	Short Description	Article No.
DP910S	Frequency Input (FI2-Ex) Input for dry contact or NAMUR initiator.	3KDE175361L9100
DP910B	Frequency Input (FI2-B) Input for dry contact or NAMUR initiator.	3KDE175362L9100
DP910N	Frequency Input (FI2) Input for dry contact or NAMUR initiator.	3KDE175363L9100

## Technical data

### Technical data DP910S/B/N

#### Input

No-load voltage	8 VDC
Short-circuit current	4...5 mA
Switching hysteresis	0.2 mA
Short-circuit detection	300...350 Ohm
Line-break detection	0.1...0.2 mA
Input frequency	Max. 4 kHz, 1.25 kHz w. direction recognition
Counter	30 bit (29 bit and digit sign)

#### Explosion protection (type ...S)

PTB 00 ATEX 2180  
II 2 (1) G EEx ib [ia] IIC T4

#### Explosion protection (type ...B)

PTB 03 ATEX 2078  
II (1) G [EEx ia] IIB/IIC  
PTB 03 ATEX 2079  
II 3 G EEx nA II T4

Max. short-circuit current	$I_o = 44 \text{ mA}$
Max. voltage	$U_o = 9.6 \text{ V}$
Max. power	$P_o = 106 \text{ mW}$
External inductance	$L_o = 1 \text{ mH}$
External capacitance	$C_o = 1100 \text{ nF}$

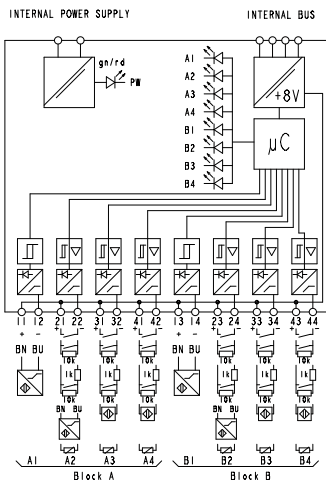





## 5.2.8 Analog input AI910S/B/N

- Power supply for 4...20 mA loop powered 2-wire transmitters
- Short and break detection
- Electrical isolation between input / bus and input / power
- Common return for all inputs
- 4 channels, EEx ia II C

Name	Short Description	Article No.
AI910S	Analog Input (AI4-Ex) Transmitter power supply, 4..20 mA.	3KDE175511L9100
AI910B	Analog Input (AI4-B) Transmitter power supply, 4..20 mA.	3KDE175512L9100
AI910N	Analog Input (AI4) Transmitter power supply, 4..20 mA.	3KDE175513L9100

## Technical data

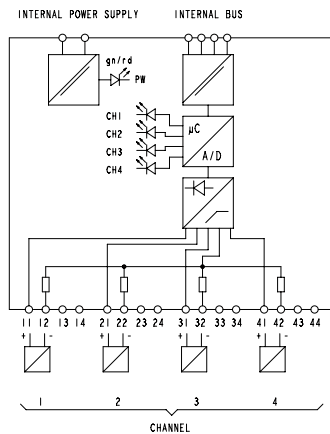

### Technical data AI910S/B/N

#### Input

Input current	4...20 mA
Transmitter supply	> 15 V (20 mA)
Internal current limitation	24...26 mA
Input impedance	240 Ohm
Residual ripple	< 100 mV
Short-circuit detection	< 5 V
Line-break detection	< 2 mA

#### Explosion protection (type ...S)

PTB 00 ATEX 2058 X  
II 2 (1G/D) G EEx [ia] ib IIC T4

#### Explosion protection (type ...B)

PTB 03 ATEX 2078  
II (1) G [EEx ia] IIB/IIC  
PTB 03 ATEX 2079  
II 3 G EEx nA II T4

Max. short-circuit current	$I_o = 93 \text{ mA}$
Max. voltage	$U_o = 22.1 \text{ V}$
Max. power	$P_o = 640 \text{ mW}$
External inductance	$L_o = 1.78 \text{ mH}$
External capacitance	$C_o = 100 \text{ nF}$



## 5.2.9 Analog input, HART, AI930S/B/N

- Power supply for 4...20 mA loop powered 2-wire transmitters
- Short and break detection
- Electrical isolation between input / bus and input / power
- Common return for all inputs
- 4 channels, EEx ia II C
- Transmission of HART frames via the fieldbus

Name	Short Description	Article No.
AI930S	Analog Input, HART (AI4H-Ex) Transmitter power supply, 4..20 mA.	3KDE175511L9300
AI930B	Analog Input, HART (AI4H-B) Transmitter power supply, 4..20 mA.	3KDE175512L9300
AI930N	Analog Input, HART (AI4H) Transmitter power supply, 4..20 mA.	3KDE175513L9300

## Technical data

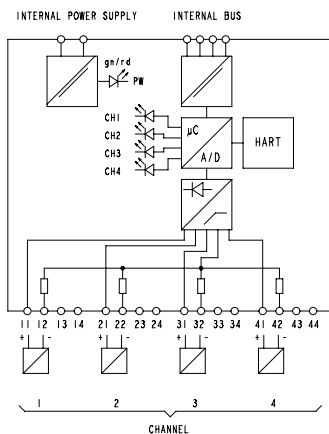

### Technical data AI930S/B/N

#### Input

Input current	4...20 mA
Transmitter supply	> 15 V (20 mA)
Internal current limitation	24...26 mA
Input impedance	240 Ohm
Residual ripple	< 100 mV
Short-circuit detection	< 5 V
Line-break detection	< 2 mA

#### Explosion protection (type ...S)

PTB 00 ATEX 2058 X  
II 2 (1G/D) G EEx [ia] ib IIC T4

#### Explosion protection (type ...B)

PTB 03 ATEX 2078  
II (1) G [EEx ia] IIB/IIC  
PTB 03 ATEX 2079  
II 3 G EEx nA II T4

Max. short-circuit current	$I_o = 93 \text{ mA}$
Max. voltage	$U_o = 22.1 \text{ V}$
Max. power	$P_o = 640 \text{ mW}$
External inductance	$L_o = 1.78 \text{ mH}$
External capacitance	$C_o = 100 \text{ nF}$



## 5.2.10 Analog input, HART, pass., AI931S/B/N

- Passive inputs for 0/4...20 mA
- Short and break detection
- Electrical isolation between input / bus and input / power
- Common return for all inputs
- 4 channels, EEx ia II C
- Transmission of HART frames via the fieldbus

Name	Short Description	Article No.
AI931S	Analog Input, HART (AI4H-Ex) Passive input, 0/4...20 mA.	3KDE175511L9310
AI931B	Analog Input, HART (AI4H-B) Passive input, 0/4...20 mA.	3KDE175512L9310
AI931N	Analog Input, HART (AI4H) Passive input, 0/4...20 mA.	3KDE175513L9310

## Technical data

### Technical data AI931S/B/N

#### Input

Input current	0/4...20 mA
Input impedance	240 Ohm
Line-break / short circuit det.	< 2 mA (4...20 mA)

#### Explosion protection (type ...S)

PTB 00 ATEX 2058 X  
II 2 (1G/D) G EEx [ia] ib IIC T4

#### Explosion protection (type ...B)

PTB 03 ATEX 2078  
II (1) G [EEx ia] IIB/IIC  
PTB 03 ATEX 2079  
II 3 G EEx nA II T4

Max. short-circuit current	$I_o = 16 \text{ mA}$
Max. voltage	$U_o = 7.2 \text{ V}$
Max. power	$P_o = 29 \text{ mW}$

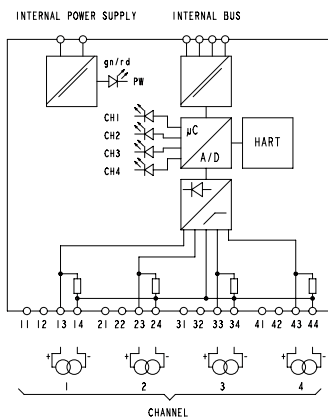



## 5.2.11 Temperature input AI950S/B/N

- Pt 100, Pt 1000, Ni 100, 0...3 kOhm in 2-/3-/4-wire technique
- Thermocouple Type B, E, J, K, L, N, R, S, T, U, mV
- Internal or external cold junction compensation
- Short and break detection
- Electrical isolation between input / bus and input / power
- Electrical isolation channel to channel
- 4 channels, EEx ia II C

Name	Short Description	Article No.
AI950S	Temperature (TI4-Ex)  Pt100, Pt1000, Ni100 in 2-/3-/4-wire technique thermocouples type B, E, J, K, L, N, R, S, T isolated inputs channel by channel.	3KDE175521L9500
AI950B	Temperature (TI4-B)  Pt100, Pt1000, Ni100 in 2-/3-/4-wire technique thermocouples type B, E, J, K, L, N, R, S, T isolated inputs channel by channel.	3KDE175522L9500
AI950N	Temperature (TI4)  Pt100, Pt1000, Ni100 in 2-/3-/4-wire technique thermocouples type B, E, J, K, L, N, R, S, T isolated inputs channel by channel.	3KDE175523L9500

## Technical data

### Technical data AI950S/B/N

#### Input

##### Input (Pt 100, Pt 1000)

Wire resistance (4 wire)	< 50 Ohm for each wire
Wire resistance (3 wire)	0...10 Ohm symmetric
Wire resistance (2 wire)	< 10 Ohm
Short-circuit detection	< 5 Ohm
Sensor, line-break detection	> 10 kOhm

##### Input (Thermocouple)

Line-break detection	< 100 nA, > 150 mV
----------------------	--------------------

##### Explosion protection (type ...S)

PTB 00 ATEX 2182  
II 2(1) G EEx ib [ia] IIC T4

##### Explosion protection (type ...B)

PTB 00 ATEX 2078  
II (1) G [EEx ia] IIB/IIC  
PTB 00 ATEX 2079  
II 3 G EEx nA II T4

Max. short-circuit current	$I_o = 25 \text{ mA}$
Max. voltage	$U_o = 5.5 \text{ V}$
Max. power	$P_o = 35 \text{ mW}$
External inductance	$L_o = 2 \text{ mH}$
External capacitance	$C_o = 1600 \text{ nF}$

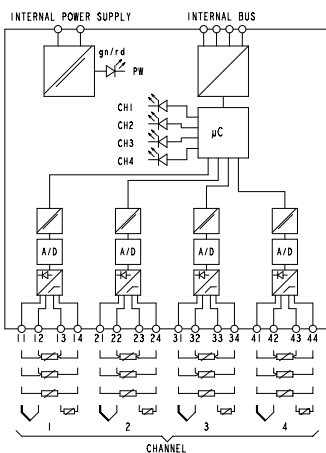



## 5.2.12 Analog output AO910S/B/N

- Output signal 0/4...20 mA for actuators
- Short and break detection
- Electrical isolation between output / bus and output / power
- Output with common ground
- 4 channels, EEx ia II C

Name	Short Description	Article No.
AO910S	Analog Output (AO4-Ex) Output 0/4..20 mA.	3KDE175531L9100
AO910B	Analog Output (AO4-B) Output 0/4..20 mA.	3KDE175532L9100
AO910N	Analog Output (AO4) Output 0/4..20 mA.	3KDE175533L9100

## Technical data

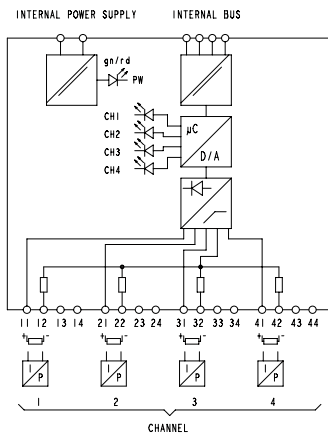

### Technical data AO910S/B/N

#### Output

Output current	0/4...20 mA
Range	0...24 mA
Load	700 Ohm (20 mA)
Short-circuit detection	< 30 Ohm ( $I_a > 2$ mA)
Line-break detection	15...18 V

#### Explosion protection (type ...S)

PTB 02 ATEX 2029  
II 2 (1G/D) G EEx [ia] ib IIC T4

#### Explosion protection (type ...B)

PTB 03 ATEX 2078  
II (1) G [EEx ia] IIB/IIC  
PTB 03 ATEX 2079  
II 3 G EEx nA II T4

Max. short-circuit current	$I_o = 93$ mA
Max. voltage	$U_o = 22.1$ V
Max. power	$P_o = 640$ mW
External inductance	$L_o = 1.78$ mH
External capacitance	$C_o = 100$ nF



## 5.2.13 Analog output, isolated AO920S/B/N

- Output signal 0/4...20 mA for actuators
- Short and break detection
- Electrical isolation between output / bus and output / power
- Electrical isolation channel to channel
- 4 channels, EEx ia II C

Name	Short Description	Article No.
AO920S	Analog Output, isolated (AO4I-Ex)  Output 0/4...20 mA. Isolated outputs channel by channel.	3KDE175531L9200
AO920B	Analog Output, isolated (AO4I-B)  Output 0/4...20 mA. Isolated outputs channel by channel.	3KDE175532L9200
AO920N	Analog Output, isolated (AO4I)  Output 0/4...20 mA. Isolated outputs channel by channel.	3KDE175533L9200

## Technical data

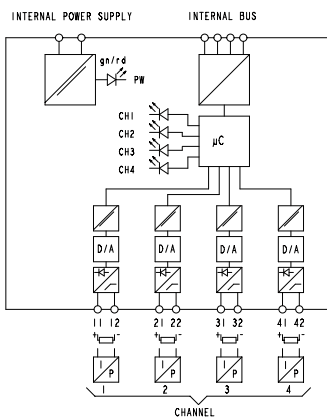

### Technical data AO920S/B/N

#### Output

Output current	0/4...20 mA
Range	0...24 mA
Load	700 Ohm (20 mA)
Short-circuit detection	100...180 Ohm
Line-break detection	< 2 mA

#### Explosion protection (type ...S)

PTB 00 ATEX 2200  
II 2 (1) G EEx e ib [ia] II C T4

#### Explosion protection (type ...B)

PTB 03 ATEX 2078  
II (1) G [EEx ia] IIB/IIC  
PTB 03 ATEX 2079  
II 3 G EEx nA II T4

Max. short-circuit current	$I_o = 80 \text{ mA}$
Max. voltage	$U_o = 18.9 \text{ V}$
Max. power	$P_o = 510 \text{ mW}$
External inductance	$L_o = 2 \text{ mH}$
External capacitance	$C_o = 100 \text{ nF}$



## 5.2.14 Analog output, HART, AO930S/B/N

- Output signal 0/4...20 mA for actuators
- Short and break detection
- Electrical isolation between output / bus and output / power
- Output with common ground
- 4 channels, EEx ia II C
- Transmission of HART frames via the fieldbus

Name	Short Description	Article No.
AO930S	Analog Output, HART (AO4H-Ex) Output 0/4..20 mA.	3KDE175531L9300
AO930B	Analog Output, HART (AO4H-B) Output 0/4..20 mA.	3KDE175532L9300
AO930N	Analog Output, HART (AO4H) Output 0/4..20 mA.	3KDE175533L9300

## Technical data

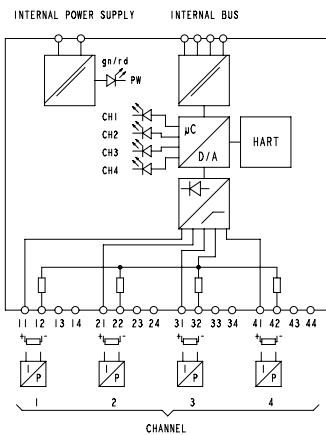

### Technical data AO930S/B/N

#### Output

Output current	0/4...20 mA
Range	0...24 mA
Load	700 Ohm (20 mA)
Short-circuit detection	< 30 Ohm ( $I_a > 2$ mA)
Line-break detection	15...18 V

#### Explosion protection (type ...S)

PTB 02 ATEX 2029  
II 2 (1G/D) G EEx [ia] ib IIC T4

#### Explosion protection (type ...B)

PTB 03 ATEX 2078  
II (1) G [EEx ia] IIB/IIC  
PTB 03 ATEX 2079  
II 3 G EEx nA II T4

Max. short-circuit current	$I_o = 93$ mA
Max. voltage	$U_o = 22.1$ V
Max. power	$P_o = 640$ mW
External inductance	$L_o = 1.78$ mH
External capacitance	$C_o = 100$ nF



## 5.2.15 Field housing FH660S, FH680S

- Stainless steel field housing for extended termination unit
- Prepared for wall mounting
- Optional isolated shielding bar or terminals
- Mounting in Zone 1 or Zone 2

Name	Short Description	Article No.
FH660S - 0000	Empty field housing, without system certificate	3KDE175804L
FH660S - 0100	Field housing Including the following components: Termination Unit (backplane) TU921S 1 Power supply filter BP901S.	3KDE175804V0100
FH660S - 1100	Field housing Including the following components: Termination Unit (backplane) TU921S 2 Terminals (UK10N) 1 Power supply filter BP901S.	3KDE175804V1100
FH660S - 1110	Field housing Including the following components: Termination Unit (backplane) TU921S 2 Terminals (UK10N) 1 Power supply filter BP901S 1 Switch.	3KDE175804V1110
FH660S - 0200	Field housing Including the following components: Termination Unit (backplane) TU921S 2 Power supply filters BP901S.	3KDE175804V0200
FH660S - 2200	Field housing Including the following components: Termination Unit (backplane) TU921S 4 Terminals (UK10N) 2 Power supply filters BP901S.	3KDE175804V2200
FH660S - 2220	Field housing Including the following components: Termination Unit (backplane) TU921S 4 Terminals (UK10N) 2 Power supply filters BP901S 2 Switches.	3KDE175804V2220

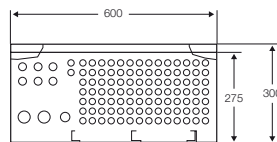

Bottom view FH660S

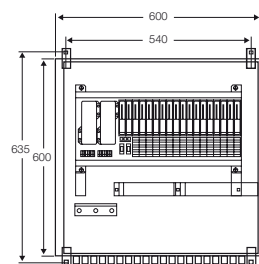

Front (inside) view FH660S

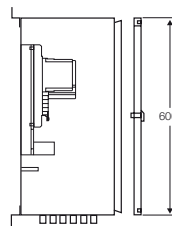

Side view FH660S



Name	Short Description	Article No.
FH680S - 0000	Empty field housing, without system certificate	3KDE175811L
FH680S - 0100	Field housing Including the following components: Termination Unit (backplane) TU921S 1 Power supply filter BP901S.	3KDE175811V0100
FH680S - 0110	Field housing Including the following components: Termination Unit (backplane) TU921S 1 Power supply filter BP901S 1 Switch.	3KDE175811V0110
FH680S - 0200	Field housing Including the following components: Termination Unit (backplane) TU921S 2 Power supply filters BP901S.	3KDE175811V0200
FH680S - 0220	Field housing Including the following components: Termination Unit (backplane) TU921S 2 Power supply filters BP901S 2 Switches.	3KDE175811V0220

## Technical data

### Technical data FH660S/FH680S

<b>Explosion protection (type ...S)</b>	PTB 02 ATEX 1133
Type of protection	II 2(1)G EEx edm ia/ib [ia] IIC T4

### General Data FH660S

External dimensions (W x H x D)	600 x 600 x 300 mm
Protection degree	IP 66 (EN 60529)
Drain plug/breather	M25, IP 56
Door hinges	Left hand side
Material	M6, stainless steel 1.4301
Cable gland	Brass (chromium-plated)
for central power	6 x M20 / 2 x M32
cable diameter	8.5...13 mm / 17.5...25 mm
for field signals and fieldbus	100 x M16
cable diameter	6...11 mm
External earth	M6, stainless steel 1.4301
Weight	
without S900 Process I/O	Approx. 24 kg
fully equipped	Approx. 33 kg

### General Data FH680S

External dimensions (W x H x D)	600 x 800 x 300 mm
Protection degree	IP 66 (EN 60529)
Drain plug/breather	M25, IP 56
Door hinges	Left hand side
Material	M6, stainless steel 1.4301
Cable gland	Brass (chromium-plated)
for central power	6 x M20 / 2 x M32
cable diameter	8.5...13 mm / 17.5...25 mm
for field signals and fieldbus	100 x M16
cable diameter	6...11 mm
External earth	M6, stainless steel 1.4301
Weight	
without S900 Process I/O	Approx. 31 kg
fully equipped	Approx. 40 kg

## 5.2.16 Field Housing roof

Name	Short Description	Article No.
S900 - BI100	Field Housing roof	3KDE175831L1000
	Weather protection. Fits to all field housing.	



## 5.2.17 Compact box CB220S/B/N

- Field housing for power supply and communication interface
- Mounting of max. 4 I/O modules
- Preselection of fieldbus address (0 ... 99)
- Separation of function level and wiring level
- Mounting in Zone 1 or Zone 2

Name	Short Description	Article No.
CB220S	Compact-Box  For power supply SA911S, communication interface CI920S and four I/O modules S900 type S (Delivery includes CD910).	3KDE175611L2210
CB220B	Compact-Box  For power supply SA911B, communication interface CI920B and four I/O modules S900 type B (Delivery includes CD910).	3KDE175612L2210
CB220N	Compact-Box  For power supply SA911N, communication interface CI920N and four I/O modules S900 type N (Delivery includes CD910).	3KDE175613L2210

## Technical data

### Technical data CB220S/B/N

#### I/O modules and communication interface

Material	PC
Fire protection class	V2, UL 94 (DIN IEC 707)
Colour (light grey)	RAL 9002
External dimensions (W x H x D)	20 x 104 x 104 mm
Weight	Approx. 0.15 kg
Test voltage (fieldbus, PS, I/O)	1500 V
Test voltage (fieldbus -> I/O)	500 V (intrinsically safe Profibus)
Test voltage (I/O -> I/O)	500 V (with el. isolation)

<b>Mounting</b>	Zone1/Zone 2 (modules S/B only)
-----------------	---------------------------------

Operating temperature	
Horizontal mounting	-20 °C...60 °C, Observe equipping !
Vertical mounting	Not allowed
Storage temperature	-40 °C...85 °C

<b>Fieldbus connection</b>	PROFIBUS DP
----------------------------	-------------

Preselection of bus address	0 ... 99 (rotary switch)
Bus termination	(see manual)

#### Standards

Transport / shock	15 g (IEC 68-2-27)
Function / Vibration	2 g (IEC 68-2-6)
Reference conditions	IEC 60770
EMC	EN 61326
Humidity	IEC 60654, T 1-4
Relative humidity	< 85% (annual average)
Condensation	Short duration, commissioning
Corrosive gases	ANSI/ISA S71.04 G3 Harsh Group A DIN EN 60068-2-60 Method 4

## System architecture

System architecture CB200S/B/N	
I/O modules per station	Max. 4
No. of channels	2, 4, 6 and 8 channel
Bus length (copper)	200 / 400 m (1.5 / 0.5 Mbaud)
<b>CB220 in Zone 1 (type S)</b>	
Mounting possibilities	Safe area, Zone 2, Zone 1
Stations / isolating repeater	Max. 10 stations type S
<b>CB220 in Zone 2 (type B)</b>	
Mounting possibilities	Safe area, Zone 2
Stations / isolating repeater	Max. 10 stations type B
<b>CB220 in safe area (type N)</b>	
Mounting possibilities	Safe area
Stations per bus line	PROFIBUS non-Ex standard
<b>General Data</b>	
Protection class	IP66 (EN60529)
Door hinges	Left hand side
Material	Aluminium
Colour (light grey)	RAL 9002
External dimensions (W x H x D)	208 x 278 x 153 mm
<b>Weight</b>	
Only CB220	Approx. 3.8 kg
Fully equipped	Approx. 5.8 kg
<b>Cable gland</b>	
For central power	Brass (chromium-plated)
Cable diameter	1 x M20
For field signals and fieldbus	8...12 mm
Cable diameter	12 x M16
	6...9 mm
External earth	M6, stainless steel 1.4301
Fastening drillings	4 x 6.8 mm diameter
<b>Terminals</b>	
System power terminals	EEx e (black)
Wire CSA	0.5 ... 2.5 mm <sup>2</sup>
Connection	Screw terminals
I/O and fieldbus terminals (type N)	Black
I/O and fieldbus terminals (type B)	EEx i (blue)
I/O and fieldbus terminals (type S)	EEx i (blue)
Wire CSA	0.08 ... 2.5 mm <sup>2</sup>
Connection	Spring loaded
<b>Power</b>	
Supply voltage	24 VDC (19.2...32 V)
Max. current consumption	See power supply
Total power loss	See power supply
<b>Explosion protection (type ...S)</b>	
	PTB 04 ATEX 2054
	II 2(1)G EEx em ib/ia IIC T4
<b>Explosion protection (type ...B)</b>	
	PTB 04 ATEX 2093
	II (1 / 2)G [EEx ib/ia]
	IIB/IICPTB 04 ATEX 2094
	II 3 G EEx nA II T4



illustration similar

## 5.2.18 Power supply SA911S/B/N for CB220x

- Powering of communication interfaces and I/O modules
- Hot swap capability (SA911S in Zone 1, SA911B in Zone 2)

Name	Short Description	Article No.
SA911S	Power supply for CB220S For 24 VDC. The power supply filter type BP901S is not required.	3KDE175611L9110
SA911B	Power supply for CB220B For 24 VDC. The power supply filter type BP 901S is not required.	3KDE175612L9110
SA911N	Power supply for CB220N For 24 VDC. The power supply filter type BP901S is not required.	3KDE175613L9110

## Technical data

### Technical data SA911S/B/N

#### Input

Power supply (PS)	24 VDC (19.2...32 V)
Max. current consumption	< 1.25 A / 24 V; < 1.56 A / 19.2 V
Total power loss	< 30 Watt

#### Output

Available power for modules	< 27 Watt
-----------------------------	-----------

#### Explosion protection

SA911S	PTB 04 ATEX 2054
SA911B	PTB 04 ATEX 2093

#### Type of protection

SA911S	II2G EEx em[ib] IIC T4
SA911B	II (2) G [EEx ib] IIB/IIC PTB 04 ATEX 2094 II 3 G EEx nA II T4

#### Diagnosis

System / Module power on	LED green / green
--------------------------	-------------------

#### General data

External dimensions (W x H x D)	45 x 135 x 105 mm
Weight	
SA911S, -B	Approx. 1.2 kg
SA911N	Approx. 0.8 kg

## 5.2.19 Accessories for S900 Remote I/O

### 5.2.19.1 Fieldbus isolating repeater

Name	Short Description	Article No.
BI914S	Fieldbus isolating repeater  Separates an intrinsically safe RS485 fieldbus from a non intrinsically safe RS485 fieldbus with bus termination mounted in DIN rail mounted housing with IP20 protection. (Ready for order as from March 2009).	3BDH000649R1

### 5.2.19.2 Ring-coupler

Name	Short Description	Article No.
BI923S	Ring-coupler RS485 / FO - intrinsically safe - Slave  Separates an intrinsically safe fibre optic ring from a non intrinsically safe RS485 fieldbus. BARTEC - 07-7311-97WP5000 Mounted in DIN rail mounted housing with IP20 protection (Slave).	3KDE175831L9230
BI924S	Ring-coupler RS485 / FO intrinsically safe - Master  Separates an intrinsically safe fibre optic ring from a non intrinsically safe RS485 fieldbus. BARTEC - 07-7311-97WP5200 Mounted in DIN rail mounted housing with IP20 protection (Master).	3KDE175831L9240
BI933S	Ring-coupler RS485 / FO  Separates an intrinsically safe fibre optic ring from an intrinsically safe RS485 fieldbus. Mounted in separate field housing BARTEC - 07-3103-2512/177M (Slave).	3KDE175831L9330

## 5.2.20 Additional accessories

Name	Short Description	Article No.
BP910S	Intrinsically safe PROFIBUS-DP connector  D-SUB Connector (color blue). For operating the intrinsically safe PROFIBUS-DP.	3KDE175831L9100
IP920	Module housing  IP20 protection for empty slots on the termination unit. For use in S900 S, B, and N systems.	3KDE175831L9200
IL910	Insert labels  380 pcs.	3KDE175839L9101

## 5.2.21 Software

Name	Short Description	Article No.
BI992	ABB DTM S900 DP - Licence in combination with ABB DCS systems only  For parameterization and configuration of the S900 station according to FDT 1.2, for all PROFIBUS-addresses inclusive HART. (Observe Release Notes).	3KDE175839L9920
CD910	Additional Software  CD incl. S900 Documentation, Certificates, GSD (file) ABB DTM S900 DP. CD will be delivered with all TU921 and CB220 deliveries.	3KDE175839L9100





# Chapter 6 Network components



## 6.1 PROFIBUS network components

Name	Short Description	Article No.
RLM01	<p>PROFIBUS Redundancy Link Module for PROFIBUS line redundancy</p> <p>Converts a non-redundant PROFIBUS line to two redundant RS485 lines or vice versa. Germanischer Lloyd (GL) certified (cat. A,B,C,D) in connection with power supply filter (3BDZ000397R1).</p>	3BDZ000398R1
Power Supply Filter	<p>Power Supply Filter (surge) 24 VDC</p> <p>Mandatory to fulfill the requirements of Germanischer Lloyd (GL).</p>	3BDZ000397R1
PCO 010	<p>PROFIBUS DP connector, standard</p> <p>Max. 12 Mbit/s, 35° cable outlet, IP40, without bus termination.</p>	3BDZ000370R1
PCO 011	<p>PROFIBUS DP connector with bus termination</p> <p>Max. 12 Mbit/s, 35° cable outlet, IP40, switchable bus termination.</p>	3BDZ000371R1
PCO 012	<p>PROFIBUS DP connector with bus termination and adapter</p> <p>Max. 12 Mbit/s, 35° cable outlet, IP40, switchable bus termination, programming connection SUB-D.</p>	3BDZ000372R1

## 6.2 FOUNDATION Fieldbus network components

Name	Short Description	Article No.
LD 800HSE	Linking Device LD 800HSE  LD 800 HSE module for DIN rail mounting with 4 H1 links and one HSE connector. The module itself needs external 24 VDC power supply. H1 links must be powered separately.	3BDH000320R02
Redundancy Link Cable	Redundancy Link Cable, 0.5 m  Redundancy Link Cable links two LD 800HSE to a redundant set of devices.	3BDH000281R1
Media CD LD 800HSE	Version 3.2, English  Documentation in pdf-format, tools, capabilities file, and bitmaps for LD 800HSE.	3BDD011678R0401
Media CD LD 800HSE	Version 3.3.0, English  Documentation in pdf-format, tools, capabilities file, and bitmaps for LD 800HSE.	3BDD011678R0501
Printed User Instructions LD 800HSE	Version 3.2, English  Describes in detail the FOUNDATION Fieldbus Linking Device LD 800HSE features, hardware installation, configuration, and diagnostics.	3BDD011677R0401
Printed User Instructions LD 800HSE	Version 3.3.0, English  Describes in detail the FOUNDATION Fieldbus Linking Device LD 800HSE features, hardware installation, configuration, and diagnostics.	3BDD011677R0501

# Chapter 7 The Operator Level with DigiVis



The DigiVis software, based on Microsoft Windows as a graphical user interface, enhances the ease of use and the performance of process operation.

In addition, you can also use any PC peripherals such as monitors, printers, mice and keyboards that are available on the market for Windows-compliant PCs.

The operation and observation (DigiVis) and configuration (Control Builder F) functions can also be performed together on one PC.



For operation DigiVis offers the following features:

- Transparent and rapid operation due to a clearly structured information hierarchy
- User-specific function key assignment for fast display selection
- A large number of pre-engineered displays
- Rapid selection of the correct measuring points in case of process alarms
- Trend display with archiving
- Logging of all operator actions, including name and timestamp
- System diagnostics, even down to the field device, allowing extended field device diagnostics
- Uniform process alarm and message concept and clearly arranged display of messages and operator hints
- Up to 16 user groups / access profiles, with up to 1000 users, specific password for each user (with optional Security Lock software)
- Various language versions: English, German, Spanish, Swedish, Russian, Polish, French, Chinese and Japanese
- A control aspect, providing access to automatically generated dynamic interlocking displays for the selected tag (in connection with OPC or trend server)
- External aspects, providing access to additional information such as PDF documentation, live videos from the plant, standard operational procedures (SOPs), etc.
- Configurable voice output on the PC for process alarms
- Dual-monitor operation on a single PC, with one mouse and one keyboard

The process visualization is supported by plant-specific custom graphic displays, faceplates for tags and up to 15 plant areas with plain text labeling.

## Plant-specific displays

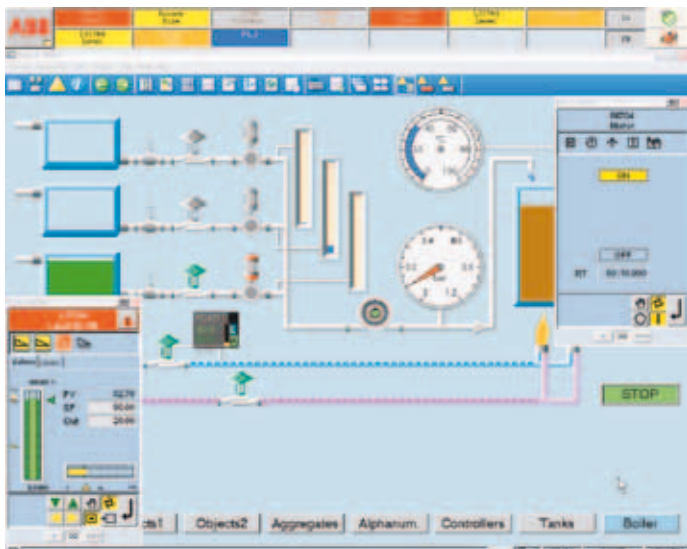

Figure 10: Graphic display with faceplates

Plant-specific displays geared to the specific demands of the plant operator can be configured to depict process activities.

Static sections of the graphic displays can be created using the graphics editor. In addition, you also have the option of inserting such static sections in the form of bitmaps, created by any other graphic editor, scanner, or digital photograph. Current process data or process states can be animated at every suitable position using features such as bar graphs, level indicators and trend windows.

Depending on process states, graphic symbols can, flash, change color and position or be replaced in the graphic display. Tags can be viewed either via faceplates in the graphic displays or via the standard group displays.

Display selector fields or buttons can be used to setup a specific selection hierarchy within custom graphics for operation. The number of custom graphics available in DigiVis is limited only by the hard disk capacity.

## Pre-engineered, ready-to-use displays

Pre-engineered displays are adapted to the needs of process control engineering with regard to structure and information content.

The following displays are available:

- Overview display
- Group display
- Faceplate
- Sequential Function Cart (SFC) display
- Time scheduler display
- Trend display
- Web display
- Message list and operator hint list
- Logs
- System display for hardware diagnostics

Therefore, most functions already have fully prepared displays for operation and observation, and can be used without additional work.

## Overview display

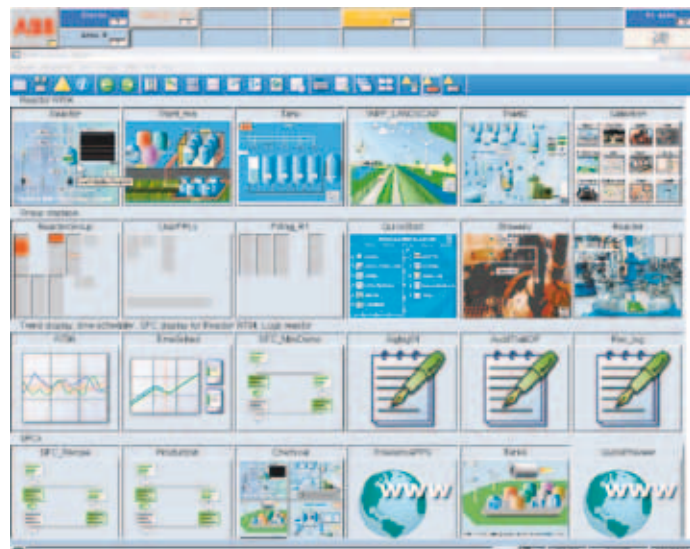

Figure 11: Overview display

The process information for the entire plant is presented in a condensed manner in a single overview display. It offers facilities for selecting the group, graphic, SFC, Web, time scheduler and trend displays. Logs can also be called up directly from the overview display. Up to 96 displays can be shown in the overview display. The group display symbols within the overview display also feature dynamic updating of tags, allowing disturbance states to be detected rapidly through appropriate symbols and colors. If required, you can also set a graphic display of your choice as overview display. It then replaces the standardized display.

## Faceplates

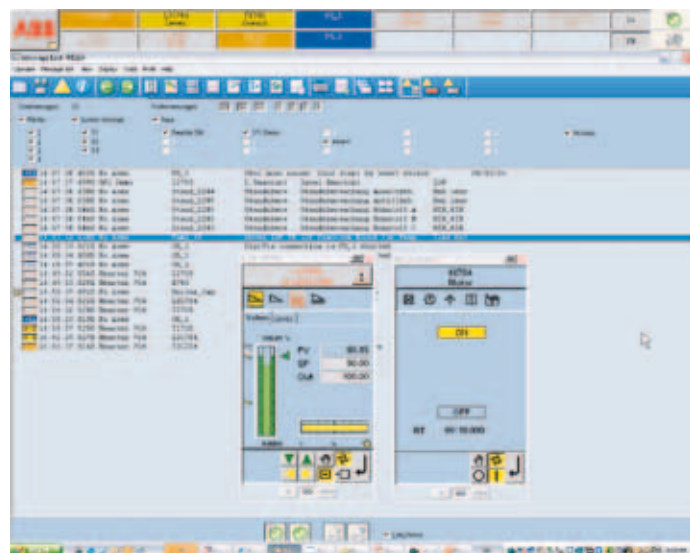

Figure 12: Faceplates

Faceplates allow both overview and detailed information to be obtained simultaneously. Since faceplates are predefined, they are available immediately in the system following the definition of a tag, without any additional programming. This is also the case for user-defined faceplates. Therefore, faceplates can be displayed together with standardized and freely designed displays.



## Group display



Figure 13: Group display

The group display is a combination of several faceplates and contains detailed information about associated tags. All functions, including controllers, PID-loops, time and monitoring functions as well as open-loop control functions, can be displayed and operated.

To provide a quick source of information, analog values are displayed as colored bars. To allow more precise reading, they are also shown as alphanumeric values. Pending disturbance states in the respective variables can be detected immediately through a change in color and flashing, and can be acknowledged directly in the faceplate or message list. Configured limits can be additionally displayed as symbols. You can create your own faceplates for user-defined function blocks.

## SFC display

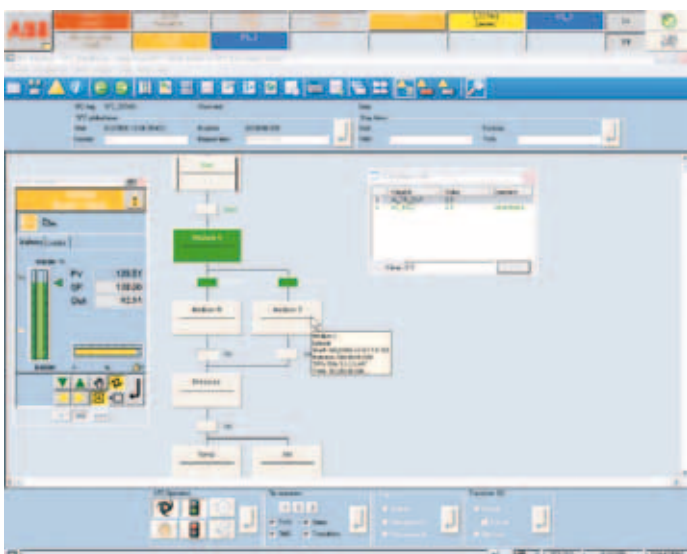

Figure 14: SFC display

The sequential function chart (SFC) based on the IEC 61131-3 standard is viewed in a standardized SFC display showing the current program state of the sequential function chart.

In the SFC display, you see the actual processing status, where already finished and coming steps are marked with different colors. Disturbance states, such as non-fulfilled process criteria or time outs can be easily detected by a color change within a criteria window for steps and transitions. Furthermore, a display selection can be configured for each step and transition. The variables shown in the criteria window can be operated.

An SFC overview display allows direct access to a step or transition, and the desired information can be selected immediately. This is particularly beneficial in the case of complex open-loop control structures, when rapid intervention by the operator is essential. The Control Aspect allows the animated display of the transition program, similar to the commissioning display in Control Builder F.

The display is generated automatically and is an alternative to the criteria window, which allows you to configure a standardized, reduced display of the criterias..

## Time scheduler display

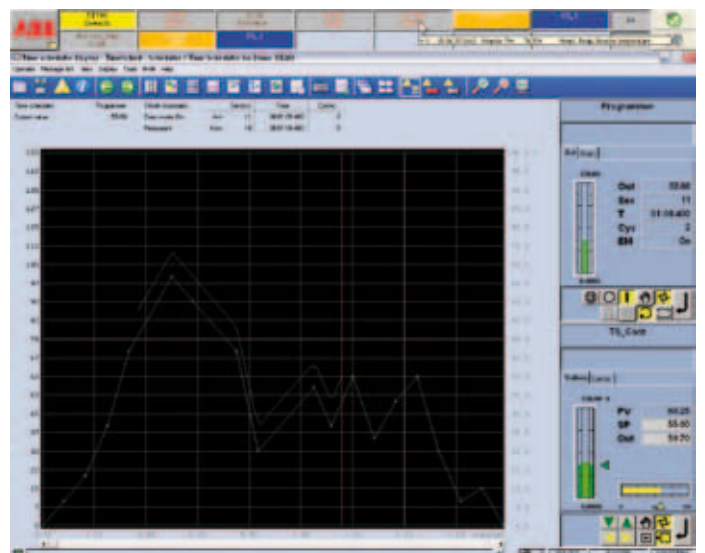

Figure 15: Time scheduler display

The time scheduler module makes it possible to define analog variables during a pre-defined time by default, e.g. as a set point value for a connected controller. The current set point is determined from a series of up to 32 configured values describing a set point curve. The time scheduler display is easy to operate. Apart from enabling the switching of operation modes, it also permits the modification of the current set point. Manual alterations to the set point are displayed in a separate curve.

A manual set point can be defined by offsetting the configured set point. A return (time-delayed) to the original value is possible at any time. A program can be executed cyclically or by stating a certain number of runs.

## Web display

The Web display provides a simple way to display web pages on the operator station, without covering the message line. For example, this allows you to observe the picture of a camera using a built-in Web server, making it easy to monitor flames or observe chimneys. However, in addition to showing Web pages, it is also possible to start other applications and display documents using this display type.

## Trend display and archiving

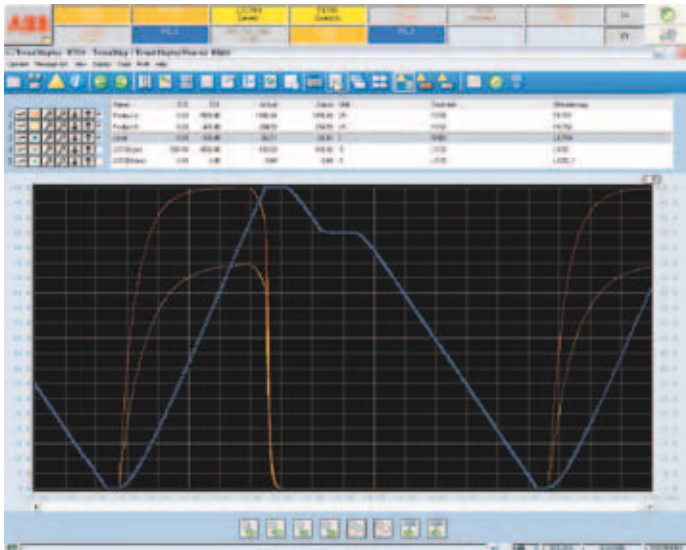

Figure 16: Trend display

The chronological sequence of analog and binary process variables can be displayed as a trend display.

The following can be shown in one trend display:

- Up to six signals in different colors
- The associated measuring point name with short text
- The current measured value with scale and unit used

The trend display can be altered by:

- Moving the time axis to show previous values
- Hiding trends
- Increasing and decreasing the signal range
- Selecting specific settings for each trend progression (e.g. color or interpolation)
- Highlighting individual trend curves
- Using a variable time range (seconds through to weeks)

If a trend display is configured with archiving, the measured values are recorded as a cyclical function of the operator station. The archived values can be backed up on any data medium or sent via file transfer protocol (FTP) to any subscriber on the Ethernet.

They are then available for further evaluations and can be exported in CSV<sup>1</sup> format using the separate DigiBrowse software. The original data is binary coded and therefore protected against manipulation.

<sup>1</sup> CSV = comma separated value, a format in which data can easily be imported into Microsoft Excel and evaluated.

## User-defined trend displays

Operators can compile any process values in a trend display themselves by selecting the required process values from a list of all variable names. No additional engineering effort is necessary. The task of archiving this trend data on the hard disk of the operator station PC can also be carried out easily in the same way.

A prerequisite for user-defined trends is that the system contains a trend server.

## 7.1 Messages & operator hints

Process disturbances are detected by the controllers and forwarded to the operator stations with a timestamp.

The Freelance 800F system allows the following message types: system alarm (S1-S3), process alarm (P1-P4) fault message and operator hint message (P5). Process alarms are divided into fault messages (P1-P3) and switching messages (P4). When parameterizing the function blocks, it is possible to assign up to 4 messages to its limit monitoring units integrated into the block. Whereas the internal controller time is generally used for the timestamp for messages, you also have the option of using a special function block to assign external timestamps to alarms. In this way, for example, you can generate an alarm from a device connected to the Modbus in the correct chronological order with the device's timestamp. Different methods of acknowledgement can be selected for each priority level. Incoming messages are displayed in different colors, along with the name and disturbed status of the tag in accordance with their priority.

### Message line

The upper area of the display is always reserved as a message line for the higher-level display of all message types from the entire process.

The message line optionally displays either the newest or oldest messages, as well as buttons for acknowledging messages and viewing operator hints. There is also a field for indicating overflow, a field for acknowledging alarms and a field showing the number of unacknowledged messages in the message list. For quick operation, the faceplate of the disturbed tag can be accessed directly from the message line.

Operators can choose between three different message line views:

- Standard view

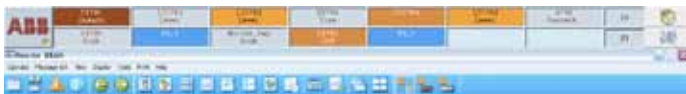

- Area view



- List view

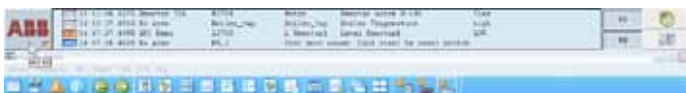

### Message list

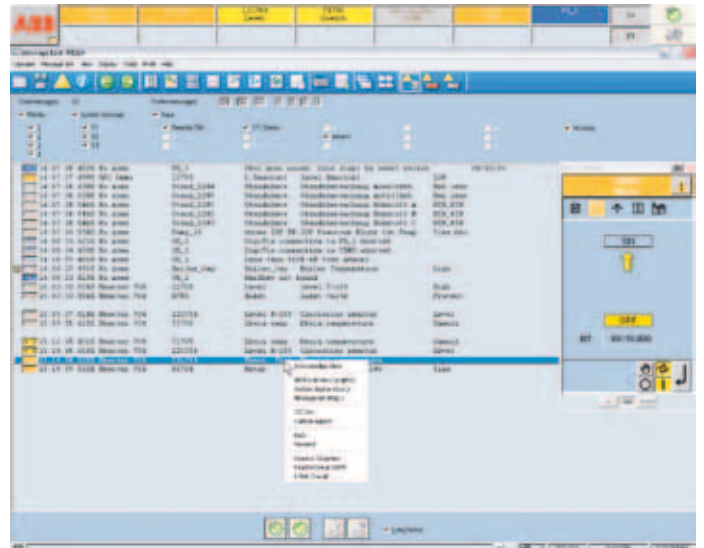

Figure 17: Message list

The message list offers an overview of all pending messages. It features a chronological list of fault, switch and system alarm messages. The latest message is placed at the beginning or end of the list, as configured. This message sequence can be altered by configuration.

Just as in the message line, different priorities are color-coded. Messages can be acknowledged both by block and by page. To provide a better overview, the user can filter certain priorities or plant areas on the screen display.

Other displays belonging to the tag, such as faceplates, graphic or trend displays, can be selected via tag specific aspect navigation from the message list simply by a right-click.



## Operator hint list

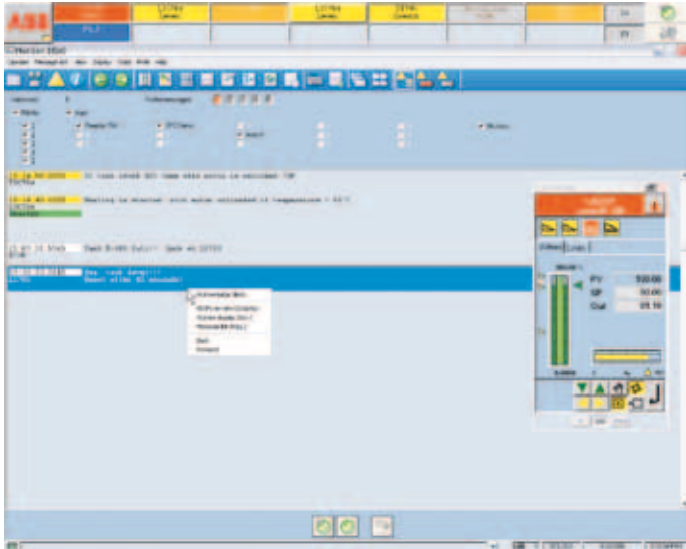

Figure 18: Operator hint list

A hint for the operator can be configured for each process alarm or event. Hints are intended to inform the operator about the cause of the message or about the procedure to be adopted for eliminating a process alarm. If necessary, hints can also provide further user help.

All configured hints are displayed in the hint list. Faceplates or other displays can also be called up directly from the hint list to operate a tag or analyze critical process situations.

## Logging

Logs are used to document events, states and sequences from the process. Log files can be displayed on the screen, printed, and saved on a CD, DVD, or memory stick for further evaluation.

In addition, the archived files can be automatically sent to any subscriber on the Ethernet via the file transfer protocol. The DigiBrowse software makes it possible to view the data and to convert it into ASCII (CSV file) for further evaluation, for instance using Excel.

The Freelance 800F system features the following log types:

## Signal sequence log

The signal sequence log is used for logging events such as process and system messages, switching messages and hints. Even operator intervention can be logged in detail together with the user name and timestamp. The user can determine which message priorities are to be logged. Binary events can be logged with an accuracy of 2 ms for the whole system (sequence of events). Signal sequence log 1 allows the operation of a line printer in order to immediately print every alarm when it is received.

## Operation log

At certain intervals or in certain situations, the plant log records the current values or states of process variables. It can run cyclically, or can be started and stopped manually or by an event. The output format is freely configurable as table or fill-in-the-blanks text.

## Disturbance course log

The disturbance course log is used to examine the course of disturbances. The process values before and after a disturbance are recorded with a high time resolution and archived in an operator station. Four logs of each type can be configured in one operator station.

## System diagnostics

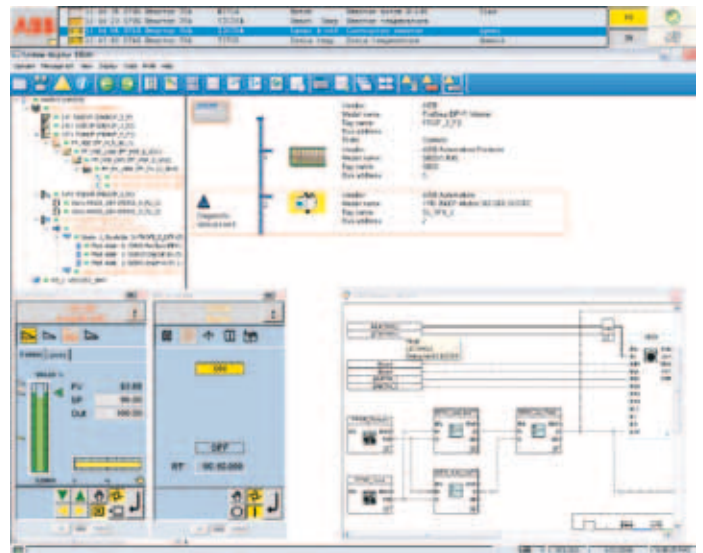

Figure 19: Easy system diagnostics with the system display

The current state of the hardware and software of a Freelance 800F system is shown in the automatically generated system display. Here, information can be obtained in various degrees of detail about the status of an individual controller to a specific field device.

The simple system display is available to all operators of a DigiVis operator station. Additional information is also available for field devices on Profibus or FOUNDATION Fieldbus.



## 7.2 Software subscription

Name	Short Description	Article No.
Software Subscription	Add to existing Software Subscription Select this item if an existing system / project is to be extended by DigiVis and / or DigiBrowse. Indicate the System ID.	3BDS008515R06

## 7.3 DigiVis languages

Name	Short Description	Article No.
Changing the current language	Changing the current language Indicate the DigiVis hardkey number and the new language. Setup CD and the documentation manuals in the chosen language are to order additional. The language change becomes part of the existing Software Management Program.	3BDS008503R06
English language	English language	3BDS008502R0601
German language	German language	3BDS008502R0603
Chinese language	Chinese language	3BDS008502R0621

## 7.4 DigiVis license V9.1

Name	Short Description	Article No.
DigiVis	DigiVis, Software License	3BDS008790R06
DigiBrowse	DigiBrowse DigiBrowse doesn't need a hardkey.	3BDS008792R06

## 7.5 DigiVis options

Name	Short Description	Article No.
WEB Display run time	<p>WEB Display run time</p> <p>Enables a DigiVis Station to execute a configured Web Display.</p> <p>Enables a Combi Station to execute a configured Web Display.</p>	3BDS008785R06
Dual Monitor Support	<p>Dual Monitor Support</p> <p>For a single operator station.</p> <p>A graphic interface with dual monitor support is required.</p> <p>See release note.</p>	3BDS008784R06
Control Aspect	<p>Control Aspect</p> <p>Display (read only) of Control Builder F function block diagrams in DigiVis.</p> <p>For data exchange you can use the Trend Server Package or the OPC Server in the Open Communication Package.</p> <p>Full version (read &amp; write) of Control Aspect (known as CBF Viewer), see price list "Engineering Tools...for ABB Process Control Systems".</p>	3BDS009973R06
Extended Diagnostic	<p>Extended Diagnostic</p> <p>A Control Builder F Professional license supporting the Security Lock function is recommended.</p> <p>Intended only for use with one DigiVis station per system.</p>	2PAA102040R06

## 7.6 DigiVis hardkeys

Name	Short Description	Article No.
Combi Hardkey	Combi Hardkey for Parallel Port Hardkey for DigiVis and Control Builder F.	3BDH000196R1
Combi Hardkey	Combi Hardkey for USB Hardkey for DigiVis and Control Builder F. Windows 2000 / XP only. DigiBrowse doesn't need a hardkey.	3BDH000196R2
DigiVis Hardkey	DigiVis Hardkey for Parallel Port	3BDH000197R1
DigiVis Hardkey	DigiVis Hardkey for USB Port Windows 2000 / XP only.	3BDH000197R2
Replacement Hardkey	Replacement Hardkey This will render the old hardkey obsolete. Licenses noted for the old hardkey will be moved to the replacement hardkey. Indicate the hardkey number of the key you want to replace.	3BDH000199R1
Change Hardkey	Change Hardkey type to USB Port For PC replacement without parallel interface. This will render the old hardkey obsolete. Licenses noted for the old hardkey will be moved to the replacement hardkey. Indicate the hardkey number of the key you want to replace.	3BDH000199R2



# Chapter 8 Configuration and commissioning with Control Builder F



Control Builder F is the engineering tool of Freelance 800F. It is used for configuration and commissioning of all automation functions. Furthermore, the operator interface DigiVis will not only be configured with Control Builder F, but the integrated graphics builder is used to create process graphics, which can dynamically indicate for example the status of a process.

The entire Freelance 800F system can be configured either online, while Control Builder F is connected to a controller, or offline. For offline configuration, no controller is necessary. The application program, that was created during offline configuration, can later on be downloaded to a controller.

In particular, this is also true for FOUNDATION Fieldbus configuration, whereby Control Builder F can be used to generate the control-in-the-field application even without any devices being available.

Control Builder F offers the following features for configuration, parameterization and commissioning:

- A single software tool for configuration of the automation functions, the operator interface with displays and logs, and fieldbus parameters:
  - Graphical configuration with powerful editors according to IEC 61131-3 in any of the following programming languages:
    - Function block diagram (FBD)
    - Instruction List (IL)
    - Ladder diagram (LD)
    - Sequential function chart (SFC)
    - Structured text (ST)
  - A function block library with more than 220 tried and tested functions, greatly exceeding the basic ones outlined in IEC 61131-3
  - An extensive macro library containing more than 200 graphic symbols, which can be extended by the user
  - A project tree for flexible program generation and transparent program structuring
  - Verification of automation functions, with the chance to find and remove errors quickly and easily
  - Convenient cross-reference function allowing variables and tags to be found easily in any editor right up to the graphic display
  - Importing and exporting of programs, displays, variables, tags and parts of the project tree
  - Password protection to prevent unauthorized project modification
  - Password protection for user-defined function blocks
  - Uniform and auto-generated system-wide graphical documentation of the entire user program, system communication and all field device parameters
  - Integrated online help
  - Project file (application) backup on any data medium (hard disk, CD, memory stick, etc.). The project file includes the complete project with all programs, graphics, controllers, and field device parameters.
  - Testing and simulation of user programs (e.g. interlocks) even without connected hardware using the controller emulator

## Project tree

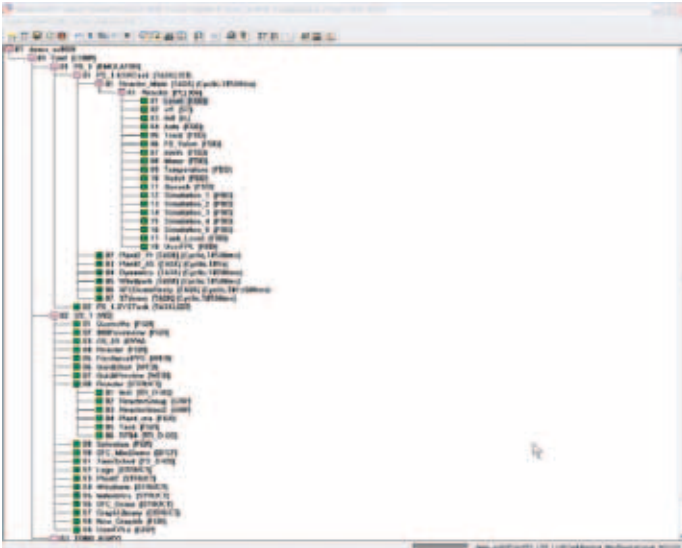

Figure 20: Project tree

The project tree is the central instrument for managing the entire user program and commissioning. All project configuration data is displayed as a tree structure.

Within the project tree:

- The configuration data in a project is structured
- Task levels and cycle times are defined
- Programs are assigned to the task levels
- Programs, displays and logs can be opened for editing, copied and moved
- Programs are checked for plausibility and their processing status displayed
- Project configuration data is exported and imported
- User programs are loaded into the process and operator stations

## Project data base

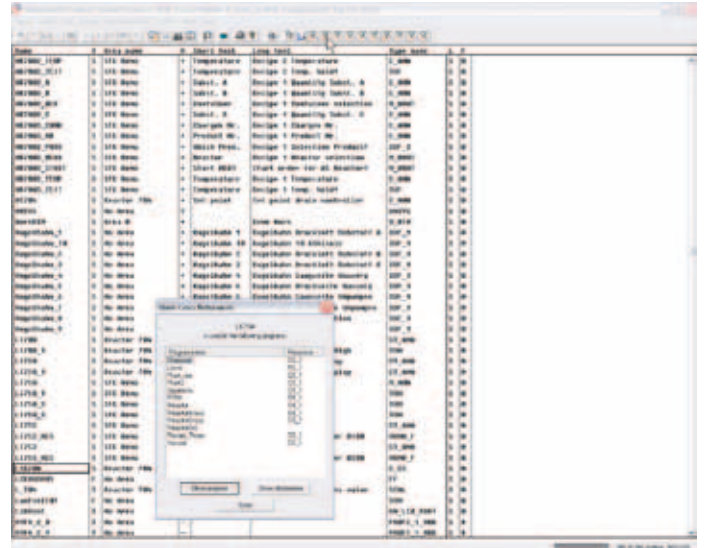

Figure 21: Tag list with cross references

All configured signals, variables and tags are managed in the Freelance 800F system as lists in a common project database:

- List of variables (inputs, outputs, internal variables)
- Tag list (function blocks)
- Graphics
- Programs

Because the database is system-wide, data only needs to be entered once, avoiding further potential errors during configuration. The single project database file makes archiving or backup ease of use.

The list of variables and tags is created automatically when a user program is generated.

Other list functions include:

- Project-wide modification of name, comments, data or module type
- Search and display based on specified search criteria
- Cross-reference function permitting rapid, systemwide location of all programs and displays in which a selected variable or tag is used

# 8.1 Configuration of functions

## Function block diagrams

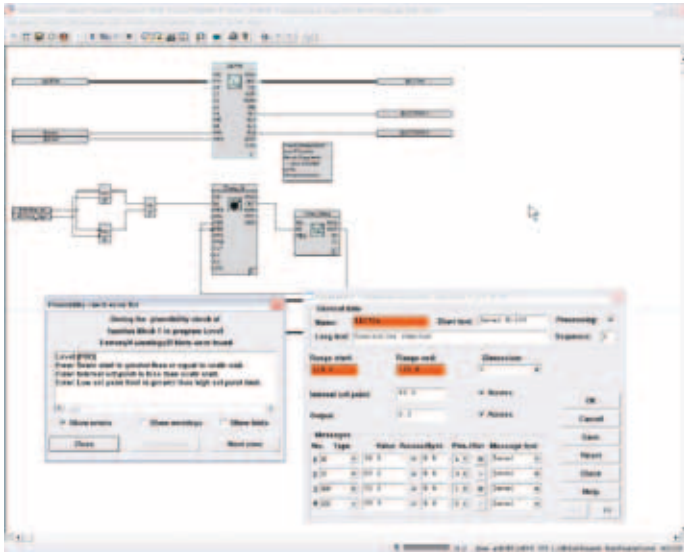

Figure 22: Program with parameterization screen and plausibility check error messages

The function block diagram (FBD) is a graphical programming language.

It keeps one or several function blocks. The inputs and outputs of the function blocks can be connected to create the signal flow. Control Builder F checks if the terminals of two function blocks can be connected.

Inputs are always displayed on the left and outputs always on the right of a function block. With variables, values can be referenced from one diagram to another one. Two different access types to variables are available: read and write access. While write variables are written by a single function block, read variables can be used by several blocks.

The layout of the terminals and the color of signal flow lines provide information about the data type.

All parameters of the function blocks are defined in the function block diagram. Clearly structured and easy to understand parameter dialogs, in which all block-specific entries can be made, are available. Once completed, the function block diagram can be verified using a plausibility check for errors or syntactic accuracy. Any errors or warnings are displayed in a list, and it is possible to navigate directly to the source of the error by simply clicking on the relevant line in that list.

The cross references in a program can be displayed for the whole system. The corresponding displays or programs can be called up directly in order to gain easy access to the variables or tags referred to.

A function block diagram (FBD program) , is configured as follows:

- Define name for FBD program
- Open editor for FBD program
- Select function blocks - Position in the graphic area
- Connect functions with the signal flow lines
  - Enter input and output variables
- Define parameters for the functions
- Check FBD program for plausibility
- Correct any syntax errors

## Sequential function charts

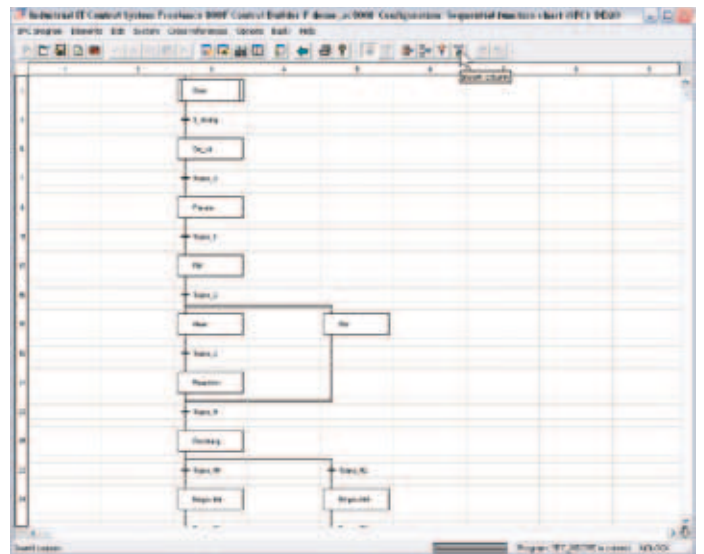

Figure 23: SFC program

The sequential function chart (SFC) readily allows transparent, graphical creation of sequential control programs. To create an SFC program, steps are configured with assigned actions (commands) and transitions with step-enabling conditions. Programs (function block diagram, ladder diagram, structured text, or instruction list) can be assigned to the steps and transitions. A further feature of the sequential function chart is the facility for creating alternative and parallel branches as well as the synchronization of these sequential structures. At the same time as the sequential function chart is configured, the SFC display for operation and observation on the operator station is generated automatically.



## Structured text

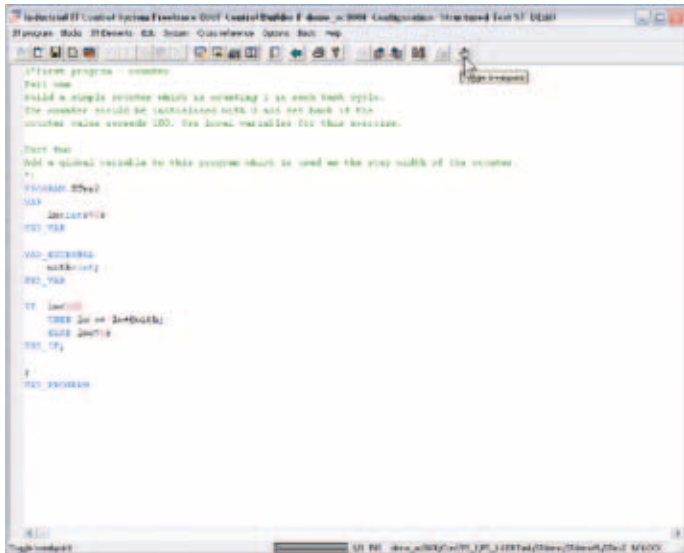

Figure 24: Structured text

Structured text is one of the text-oriented programming languages of IEC 61131-3, in which program processing is determined by instructions. All functions and function blocks can also be used in ST programs. The scope of the functions is partly covered by the ST operands. Function blocks can be used in the ST program following declaration.

Parameter definition of the function blocks also takes place in the same way as in the ladder diagram or function block diagram. In contrast to that of the function block diagram (FBD), the scope of functions of the structured text also includes conditional commands and loop commands, which are called using appropriate key words. The processing sequence is determined from the order of the commands in the ST editor. The only way to specifically change the order is to insert loop commands.

## Instruction lists

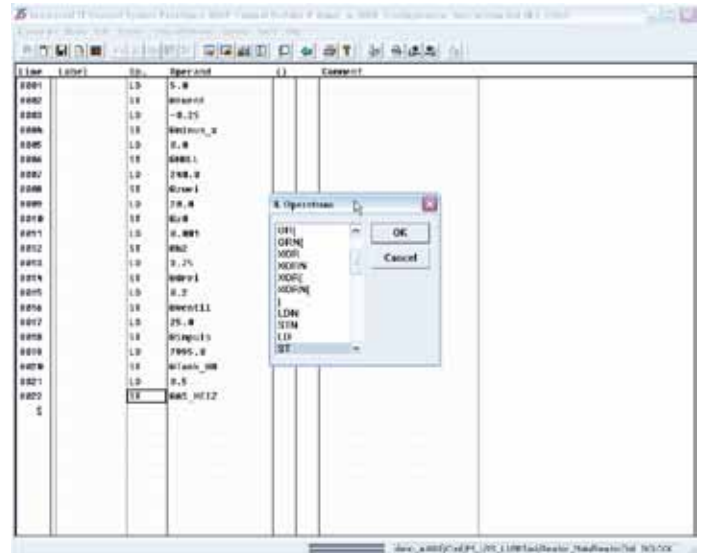

Figure 25: IL program

All Freelance 800F processing functions can be defined by the instruction list (IL). The scope of the instruction list exceeds that of the function block diagram and sequential flow chart, as jump commands and program loops can also be programmed. The operands can be displayed and entered with a selection list according to IEC 61131-3. Parameter definition of the function blocks also uses the same parameter definition screens as those used in the function block diagram.

## Ladder diagrams

Along with the function block diagram (FBD) and sequential function chart (SFC), the ladder diagram (LD) is also one of the graphical languages of the IEC 61131-3.

The ladder diagram language originates from the area of electromagnetic relay systems and describes the flow of current through individual rungs. The boundaries of a rung are defined on the right and left side by devices known as power rails, which have the logical state 1 (current is flowing). A rung is created with the elements of the ladder diagram (links, contacts and coils).

Functions and function blocks in the ladder diagram can be called up and used in the same way as in the function block diagram. Parameters are also defined for function blocks using the same parameter screens.



## Operation and observation functions

The following functions can be configured for operation and display:

- Custom graphic displays
- Web displays
- Standard display types: overview display, group display, trend display, time scheduler display
- SFC display
- Signal sequence, disturbance course and plant log
- Message list and message line
- Operator hint list.

Since the common system database is automatically accessed while configuring these functions, there is no need to re-enter the data.

## Standardized displays (pre-engineered)

Standard displays can be configured very easily using Control Builder F. To configure a group display, for example, it is only necessary to select the tags via the selection list. The entry is made automatically.

In this manner, up to 10 large analog faceplate tags can be entered per group display.

The configuration procedure for the overview display is equally simple, as the containing displays are entered from a selection list.

## Freely configurable graphic displays

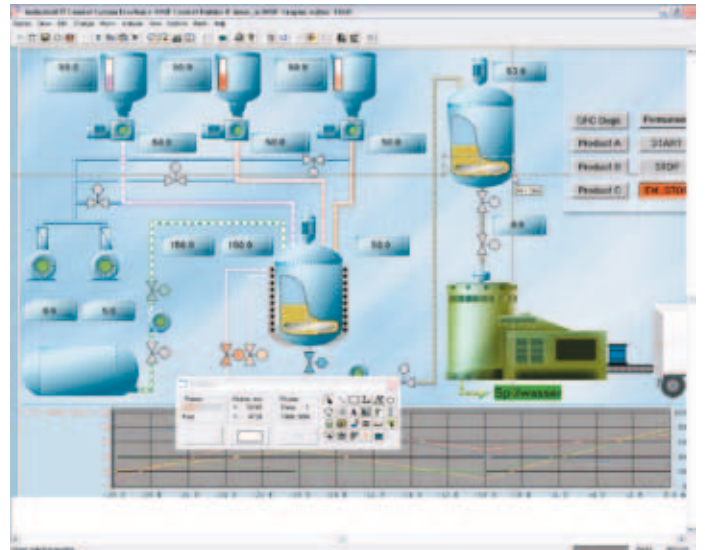

Figure 26: Graphics editor

Plant-specific graphic displays can be constructed for displaying the process. The graphic displays contain static and dynamic display elements.

The static part of the plant display – the background display – is composed of separate graphic elements which can be modified in color, line type and filling pattern and can, for example, display the schematic plant layout.

The following constructional aids in the system make it easier to create displays:

- Static elements such as lines, polylines, rectangles, polygons, ellipses, arcs and texts are created, for example, by specifying the start and end points
- Display sections already created can be duplicated, moved, rotated in 90° steps, transposed or superimposed
- The combination of several graphic elements can be saved as a macro and stored in libraries to be used when desired
- The zoom function facilitates precise construction of the individual graphic display elements
- Import of bitmap files facilitates the generation of static background displays

The process variables are displayed in the dynamic section of the display – the foreground display. Specific process variables can be visualized simply by making the display elements dynamic.

The following types of dynamic elements can be used:

Bar graphs and dynamic filling set to operate in different directions

- Superimposed numerical values and text variables
- Trend window
- Color change or symbol change to depict states
- Continuous or discrete position modifications of the graphic symbol
- Keys (buttons) for the direct execution of actions (e.g. write value or similar)
- Animated objects, e.g. mixers that turn realistically
- Tool tips

Selection fields can be defined at any position so that the operator can access any other displays using the mouse or keyboard.

## 8.2 Hardware structure

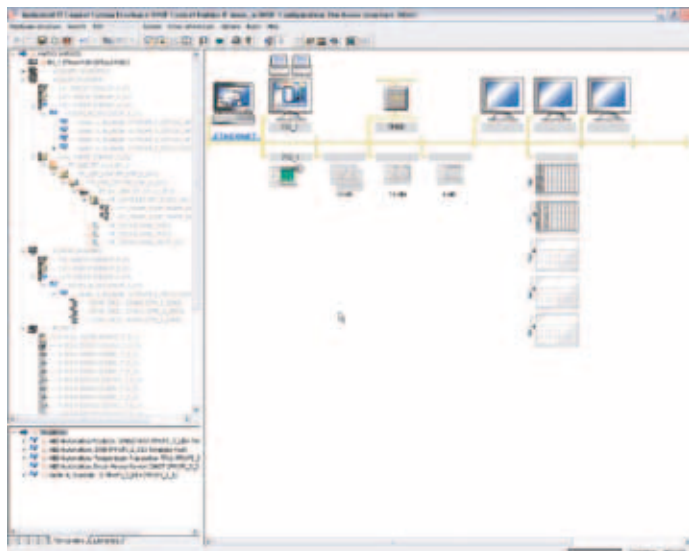

Figure 27: Definition of the hardware structure

The required hardware structure can be configured in a graphical system overview and the system communication can also be defined there. It is possible to assign particular DigiVis operator stations to specific controllers. Furthermore, detailed information can be obtained on the operator and process stations, together with their modules and the controllers with their connected fieldbus lines. In the station overview display, the operator and process stations can be equipped using selection lists. Specifications for processing, display and I/O channel assignment can be made for the individual modules of the controllers.

And all this with just a few clicks.

### Fieldbus and field device configuration

The respective bus parameters, for instance the baud rate, number of subscribers and time constants, can be set for each fieldbus module. Control Builder F also suggests a setting for the bus parameters in line with how the fieldbus is equipped. This makes work easier for those new to the subject.

## PROFIBUS

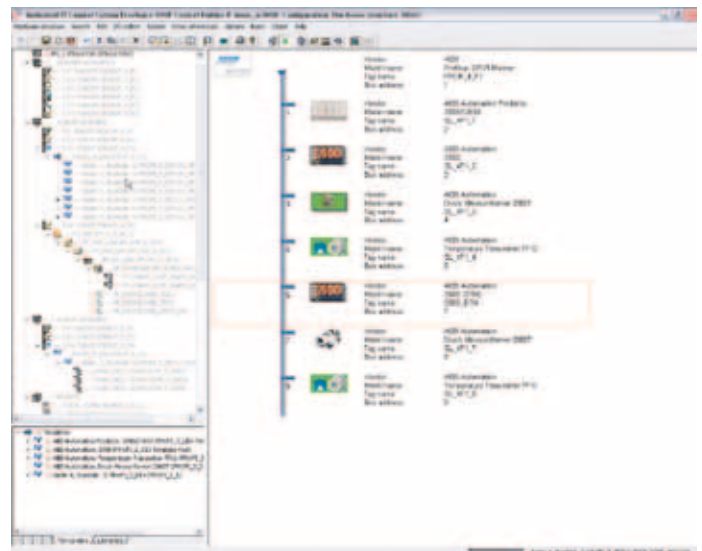

Figure 28: Configuration of the fieldbus line (PROFIBUS)

In the configuration view of the fieldbus line, new PROFIBUS slaves can be integrated into the fieldbus line using a GSD-file or FDT technology.

Using the template concept, it is also possible to integrate completely pre-configurable PROFIBUS slaves by means of drag and drop. The intelligent DP / PA Linking Device is transparent with regard to configuration, allowing PA devices to be viewed as if they were connected to the PROFIBUS DP. Parameter definition screens are then available in the device display for defining parameters for both remote I/O and PA field devices.

## HART

HART devices connected to the S800 or S900 Remote I/O can be configured with the aid of either HART templates or HART DTMs. HART templates consist of preconfigured DPV1 services which tunnel a HART command via the PROFIBUS to the HART device on the analog channel of a particular S800 or S900 module. Users can also create HART templates themselves.

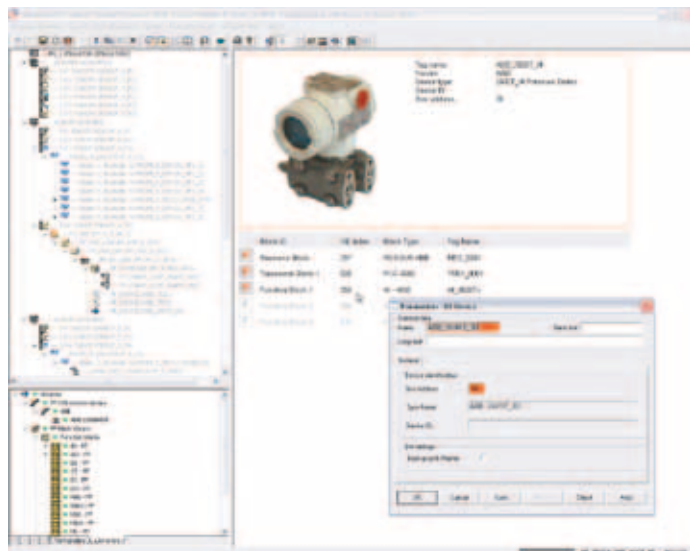

Figure 29: Configuration of the fieldbus line (FF)

The devices are configured in the feedforward part by linking the Device Description (DD) files. This makes it possible to configure the FF without the field devices being physically connected to the controllers.

The devices are configured on the H1 links of the LD 800HSE Linking Devices. As Control Builder F supports control in the field for FF devices, it is possible to configure function charts that interconnect the function blocks in the individual FF devices. Control Builder F then automatically generates a process that is passed on to the Link Active Scheduler (LAS). Redundant Link Active Schedulers are also supported. However, it is also possible to use the FF devices “only” as I/O suppliers and use the function blocks in the controllers.

## Graphical documentation

The fully graphical forward documentation allows configured programs and displays to be printed. The documentation is always up-to-date, as the current configuration data is accessed. Various sorting criteria, such as drawing numbers, assure an orderly and transparent output of the data to be documented.

The scope of documentation can be specified as desired by the user, such as:

- Program and display contents, cross references, parameter definition data and comments
- System overview and hardware configuration

The documentation specification can be stored for future use. The FBD, IL, LD, SFC and ST programs, displays, etc. are documented in the form in which they appear on the screen. Using Freelance 800F documentation management, complete or partial project documentation can be produced without effort. It is also possible to include bitmaps (such as customer logos) in the drawing footer.

## 8.3 Commissioning

During commissioning, the user programs are loaded into the operator and process stations. It is also possible to:

- Load modifications
- Start and stop process stations
- Start, stop or reset tasks
- Define and activate parameters for function blocks
- Define and activate parameters for field devices
- Display, set and track process values
- Combine any process values at any time in a trend window
- Perform version and status checks
- Perform system diagnoses right up to the field device

### Displaying process states

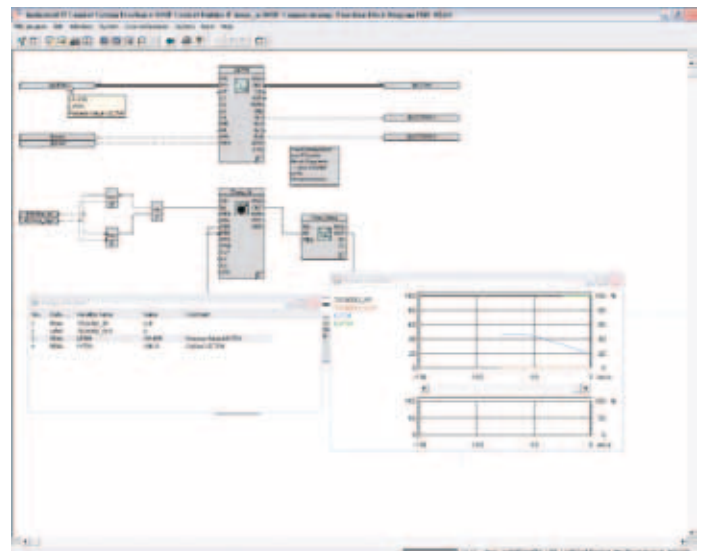

Figure 30: Trend and value window during commissioning

The editors for displaying the configured programs can also be accessed during commissioning. As opposed to during configuration, the process states of the I/O variables are also displayed in the program.

The status of the binary process signals is displayed in the FBD display by a change in the graphical representation of the signal flow lines.

Value and trend windows are available for displaying process values. They offer an optimal overview of the current process values for commissioning and test purposes.

Here, the user is not restricted to the display of I/O variables for the program currently shown on the screen. Variables from other programs and / or controllers can also be displayed, as well as values from connections between various function blocks of the current program.

## Modifying parameters

Parameters can also be modified during the commissioning phase, allowing optimal program settings for the process. These parameters can be altered from either the engineering station or the operator station.

Whether the changes made are retained permanently or only temporarily is decided by the commissioner.

Through a parameter upload, it is possible to view all parameter modifications made in a particular period of time and to select those which are to be saved in order to be used at the next cold start.

Other features allow you to force inputs and outputs and to specify new values for simulation purposes.

## Commissioning the fieldbus lines

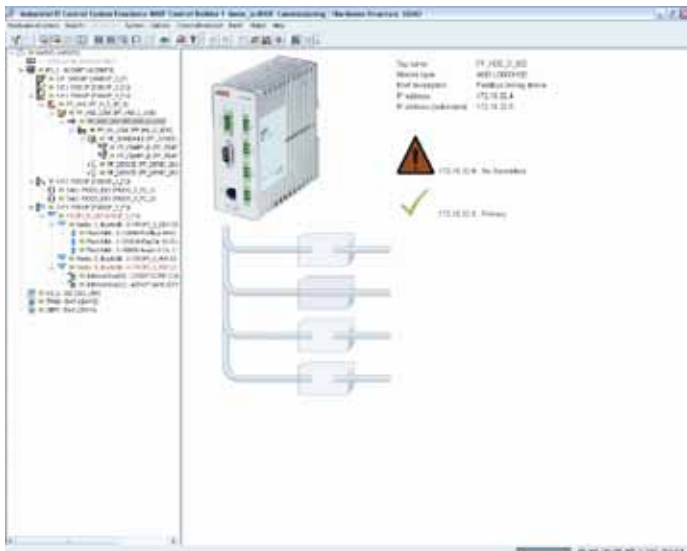

Figure 31: Online diagnosis of fieldbus components

## PROFIBUS

The fieldbus line overview shows whether the configured PROFIBUS I/O and PA devices are available. In addition, the bus can be scanned using Control Builder F in order to detect new or incorrectly configured devices. Such devices can then be given the correct address from Control Builder F via the PROFIBUS.

During commissioning, Freelance 800F allows you to compare configured parameters with the parameters that exist in the device. This makes it possible to detect device parameters that have been changed locally and transfer them to the configuration by means of uploading. When the PROFIBUS device transmits diagnoses, they can be displayed by Control Builder F. When FDT / DTM technology is used, specific diagnostic options can be used, provided that the device manufacturer has incorporated such options in the DTM.

Individual PROFIBUS devices can be removed from cyclical data traffic in order to perform maintenance without it being necessary to stop the fieldbus.

## FOUNDATION Fieldbus

Live lists displaying which devices exist are available for HSE and H1.

During commissioning, Freelance 800F allows you to compare configured parameters for the device modules with the parameters that exist in the device. This makes it possible to detect device parameters that have been changed locally and transfer them to the configuration by means of uploading.

The Link Active Scheduler (LAS) can be stopped in order to interrupt processing of the control loops in a H1 link.

## 8.4 Control Builder F languages

Name	Short Description	Article No.
Changing the current language	Changing the current language  Indicate the Control Builder F hardkey number and the new language. Setup CD and the user documentation in the chosen language are to order additional. The language change becomes part of the existing Software Management Program.	3BDS008503R06
English language	English language	3BDS008502R0601
German language	German language	3BDS008502R0603
Chinese language	Chinese language	3BDS008502R0621

## 8.5 Control Builder F license

For an executable system is necessary:

- One setup CD
- One Control Builder F license
- One hard key (part of Control Builder F license)
- One Control Software license for every used controller (station)

Name	Short Description	Article No.
Control Builder F Standard	Software License  Control Builder F Standard supports: - 16 Character Tag Names - User Defined Function Blocks (Runtime license). In addition order one Control Software license for every used controller and select one language.	3BDS008510R06
Control Builder F Professional	Software License  Control Builder F Professional supports: - all features of Control Builder F Standard - Security Lock - Creation of User Defined Function Blocks (developer license) - DTM / FDT-Support. A claim on intended function exists only in conjunction of DTM, which is approved by ABB for the use with control builder F in V9.1. In addition order one Control Software license for every used controller and select one language.	3BDS008520R06

## 8.6 Control Builder F options

Name	Short Description	Article No.
DigiVis Combi-Version	DigiVis Combi-Version Allows for engineering and operation on the same workplace (PC). Only in combination with Control Builder F.	3BDS008794R06
WEB Display Configuration	WEB Display Configuration Enables Control Builder F Standard and Professional to configure Web Displays.	3BDS008786R06

## 8.7 Control Builder F hardkeys

Name	Short Description	Article No.
Combi Hardkey	Combi Hardkey for Parallel Port Hardkey for DigiVis and Control Builder F.	3BDH000196R1
Combi Hardkey	Combi Hardkey for USB Hardkey for DigiVis and Control Builder F. Windows 2000 / XP only. DigiBrowse doesn't need a hardkey.	3BDH000196R2
Control Builder F Hardkey	Control Builder F Hardkey for Parallel Port	3BDH000198R1
Control Builder F Hardkey	Control Builder F Hardkey for USB Windows 2000 / XP only.	3BDH000198R2
Replacement Hardkey	Replacement Hardkey This will render the old hardkey obsolete. Licenses noted for the old hardkey will be moved to the replacement hardkey. Indicate the hardkey number of the key you want to replace.	3BDH000199R1
Change Hardkey	Change Hardkey type to USB Port For PC replacement without parallel interface. This will render the old hardkey obsolete. Licenses noted for the old hardkey will be moved to the replacement hardkey. Indicate the hardkey number of the key you want to replace.	3BDH000199R2



## 8.8 Control - Software license

This Price List contains software licenses for the following controllers:

- AC 800F
- AC 700F

Within a project / system all controllers must have the same control software license. This means that all controllers within a project either have to run with Control Software Basic or Control Software Advanced. For every used controller (station) one Control Software license is necessary:

- One redundancy couple = 1 controller = 1 control software license;
- Gateway (DDE, OPC) = no controller = no control software license

### 8.8.1 Basic controller

Control Software Basic supports:

- IEC 61131-3, binary and analogue
- Closed loop control (without Tune)
- Fieldbus integration (Profibus, FF) (not supported by AC 700F)
- DigiVis
- Incl. 50 basic I/Os This license releases the specified number of process station nodes (controller) in the Freelance project tree.

Name	Short Description	Article No.
Control Software license - Basic Controller	Number of supported basic controller incl. 50 I/Os each	2PAA103913R06

### 8.8.2 Additional basic I/Os

The maximum number of I/O license depends on CPU type and application. Please use DigiSize for load calculation. The number of I/Os relevant for licensing is determined by counting only those I/Os that are in use in the field.

Name	Short Description	Article No.
Control Software license - Additional basic I/Os	Set of additional 50 basic I/Os	2PAA103914R06

## 8.8.3 Advanced controller

Control Software Advanced supports:

- All features of Control Software Basic
- 800xA Operation, Process Portal B Support (Open Communication Package necessary, item G110)
- Serial Package including the following
  - Modbus Master, Modbus Slave
  - Sartorius Scale interface (not supported by AC 700F)
  - Protronic Coupling (not supported by AC 700F)
- Tune (Self tune PID)
- Sequence of Events (only Rack I/O)
- Incl. 50 advanced I/Os This license releases the specified number of process station nodes in the Freelance project tree.

Name	Short Description	Article No.
Control Software license - Advanced Controller	Number of supported advanced controller incl. 50 I/Os each	2PAA103915R06

## 8.8.4 Additional advanced I/Os

The maximum number of I/O license depends on CPU type and application. Please use DigiSize for load calculation. The number of I/Os relevant for licensing is determined by counting only those I/Os that are in use in the field.

Name	Short Description	Article No.
Control Software license - Additional advanced I/Os	Set of additional 50 advanced I/Os	2PAA103916R06

## 8.8.5 Control software options, basic

Additional options to Control Software Basic. In Control Software Advanced included. This option must be ordered for every controller, where you want to use it.

Name	Short Description	Article No.
Control Software Option	Serial Package Including the following - Modbus Master, Modbus Slave - Coupling Sartorius Scales (not supported by AC 700F) - Protronic Remote Control (not supported by AC 700F).	3BDS008751R06
Control Software Option	Tune Self tune for PID.	3BDS008752R06
Control Software Option	Sequence of Events Only in connection with Rack I/Os.	3BDS008753R06



## 8.8.6 Control software options, basic / advanced

Additional options to the Control Software Basic C100 or the Control Software Advanced E100. This option must be ordered for every controller, where you want to use it.

Name	Short Description	Article No.
Control Software Option	Batch Batch Library includes FPX and PLI. Usage of Control SW. Option Batch is granted only for DigiVis and Process Portal B. Other usages need a special release (please contact Product Management).	3BDS008756R06
Control Software Option	Interbus Not supported for new orders. Only for step up.	3BDS008757R06
Control Software Option	TeleControl Support for IEC 60870-5-101. Check whether the implemented subset of functionality meets your requirements.	3BDS008758R06
Control Software Option	CSO Gateway Maestro UX - Coupling. Until further notice a project-specific release is necessary. Please contact Product Management for information.	3BDS008760R06

## 8.8.7 Additional packages

Name	Short Description	Article No.
Open Communication Package	Open Communication Package DDE, OPC Single user license, for every single computer necessary!	3BDS008754R06
Trend Server Package	Trend Server Package For trending data on DigiVis without using trend acquisition function block. Only one Trend Server is possible per system.	3BDS008755R06
Application Programming Interface (API)	Application Programming Interface (API)	3BDS008759R06



# Chapter 9 Media and documentation

## 9.1 Product box

Name	Short Description	Article No.
Product Box	Freelance 800F, Product Box Including Software CD, Documentation CD, Manual "Getting Started".	3BDS008536R0603

## 9.2 Software CD

Name	Short Description	Article No.
Freelance 800F Software V9.1	German and English CD	3BDS008531R0603
Freelance 800F Software V9.1	Chinese and English CD	3BDS008531R0621

## 9.3 Documentation CD

Name	Short Description	Article No.
Freelance 800F Documentation V9.1	German and English CD	3BDD012530R0603



# Chapter 10 Add-ons, extensions, and service



ABB Automation is one of the world's largest suppliers of equipment, systems and services for measurement and process automation.

A crucial factor in maintaining this market position is the quality of our products, from manufacture right through to services. The DQS Certificate based on DIN ISO 9001 awarded to ABB Automation as far back as 1990 bears testimony to this fact. The same applies for the EQNet Certificate based on ISO 9000/EN 29000.

However, Freelance 800F includes more than just outstanding technical features. We have also paid a great deal of attention to rational planning, installation and modification processes, allowing you to perform engineering and maintenance activities quickly and cost-effectively. Or, if you prefer, our highly-qualified specialists can perform these activities for you, including:

- Planning and engineering
- Installation planning and execution
- Plant documentation
- Commissioning
- Technical training
- After-sales service
- Upgrades and performance improvements

Our instrumentation and control specialists, or our certified partners in system integration, will be happy to assist you in planning and implementing your automation project. ABB Automation's staff can also work with you to plan and implement the installation of a Freelance 800F system in your plant.

Under this arrangement, the ABB Automation Engineering Department will compile the specific project documentation for you. This can include functional diagrams, circuit diagrams, configuration documentation, and operating documentation including system descriptions and instructions for operation, modes of operation and plant maintenance.

At many sites, ABB Automation has its own commissioning engineers who work together with planning engineers, process instructors and operators to commission your plant, optimize it, perform a test run and hand over the system to the operator.

To make sure your operators are fully knowledgeable in the operation of the Freelance 800F compact control system, we offer a range of technical training courses.

In addition, we offer a computer-based training program for Freelance 800F on a multimedia DVD. This will provide you with the basic knowledge you need for configuration, therefore allowing you to start using the system very quickly and efficiently.

Finally, the ABB Automation Service Department provides maintenance services for all Freelance 800F systems and peripheral modules. When it comes to rectifying a fault, we provide you quickly with the necessary specialists and spare parts.





# Contact us

## **ABB AB**

### **Open Control Systems**

Västerås, Sweden

Phone: +46 (0) 21 32 50 00

Fax: +46 (0) 21 13 78 45

E-Mail: [processautomation@se.abb.com](mailto:processautomation@se.abb.com)

[www.abb.com/controlsystems](http://www.abb.com/controlsystems)

## **ABB Inc.**

### **Open Control Systems**

Wickliffe, Ohio, USA

Phone: +1 440 585 8500

Fax: +1 440 585 8756

E-Mail: [industrialitsolutions@us.abb.com](mailto:industrialitsolutions@us.abb.com)

[www.abb.com/controlsystems](http://www.abb.com/controlsystems)

## **ABB Industry Pte Ltd**

### **Open Control Systems**

Singapore

Phone: +65 6776 5711

Fax: +65 6778 0222

E-Mail: [processautomation@sg.abb.com](mailto:processautomation@sg.abb.com)

[www.abb.com/controlsystems](http://www.abb.com/controlsystems)

## **ABB Automation GmbH**

### **Open Control Systems**

Mannheim, Germany

Phone: +49 1805 26 67 76

Fax: +49 1805 77 63 29

E-Mail: [marketing.control-products@de.abb.com](mailto:marketing.control-products@de.abb.com)

[www.abb.de/controlsystems](http://www.abb.de/controlsystems)

## **Note:**

We reserve the right to make technical changes or modify the contents of this document without prior notice. With regard to purchase orders, the agreed particulars shall prevail. ABB does not accept any responsibility whatsoever for potential errors or possible lack of information in this document.

We reserve all rights in this document and in the subject matter and illustrations contained therein. Any reproduction, disclosure to third parties or utilization of its contents - in whole or in parts - is forbidden without prior written consent of ABB.

The Industrial<sup>IT</sup> wordmark is a trademark of ABB. Foundation<sup>™</sup> is a trademark of Fieldbus Foundation. HART<sup>®</sup> is a registered trademark of the HART Communication Foundation.

Intel<sup>®</sup> is a registered trademark of Intel Corporation.

Microsoft<sup>®</sup> and Windows<sup>®</sup> are registered trademarks of Microsoft Corporation.

Motorola<sup>®</sup> is a registered trademark of Motorola, Inc.

PowerPC<sup>®</sup> is a registered trademark of IBM Corporation

PROFIBUS<sup>®</sup> is a registered trademark of Profibus International.

All rights to other trademarks reside with their respective owners.

© Copyright 2009 ABB.

All rights reserved.