

# VMIVME-2170A Specifications

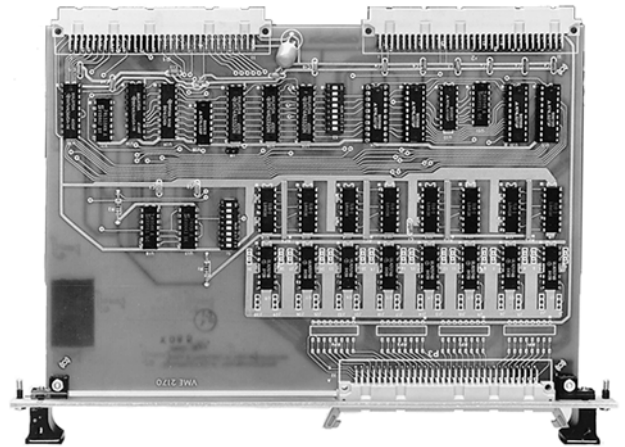

## 32-bit Optically Isolated Digital Output

### Features:

- 32 optically isolated outputs
- 2.5 or 300 mA outputs
- Externally supplied pull-up voltage for maximum isolation
- Field-configurable pull-up resistors
- Source or sink output capability with low current option
- High output voltage tolerance to 30 V normal mode
- High isolation potential; 1 kV sustained, 6 kV pulsed
- Positive or negative true options
- 8- or 16-bit data transfers
- On-board DIP switches provide 14-bit board address selection
- Double Eurocard format with front panel
- Field-selectable nonprivileged or supervisory short I/O transfers

### Applications:

- Digital control from VMEbus
- Elimination of system ground loops
- Control in high-electrical noise environments
- Control of multiple-potential system components



Ordering Options						
March 9, 2006 800-102170-000 F	A	B	C	D	E	F
VMIVME-2170A	-		0	0	0	

**A = Data Polarity**  
 1 = Positive True  
 2 = Negative True

**B = Output Current**  
 0 = 2.5 mA  
 1 = 300 mA

**CDE = 0 (Options reserved for future use)**

**F = Special Sales Order**  
 0 = Standard VME front panel w/o conformal coating  
 1 = Reserved  
 2 = Standard VME front panel w/ conformal coating

Connector Data	
Compatible Cable Connector	Panduit No. 120-964-435
Strain Relief	Panduit No. 100-000-072
PC Board Header Connector	Panduit No. 120-964-033A

**Note**

Panduit is also known as ITW/Pancon.

For Ordering Information, Call:  
 1-800-322-3616 or 1-256-880-0444 • FAX (256) 882-0859  
 Email: [info.embeddedsystems@gefanuc.com](mailto:info.embeddedsystems@gefanuc.com)  
 Web Address: [www.gefanuc.com/embedded](http://www.gefanuc.com/embedded)

Copyright © 2006 by GE Fanuc Embedded Systems  
 Specifications subject to change without notice.

## Functional Characteristics

**Introduction:** The VMIVME-2170A Optically Coupled Digital Output board consists of VMEbus compatibility logic, data control logic, four 8-bit output registers, and 32 optically isolated high-level outputs. The board is implemented as a double Eurocard form factor PC board, and provides all necessary address decoding and data transfer control logic to accept both 8- and 16-bit data transfers. Optical couplers isolate the 32 outputs from each other and from the VMEbus. Both supervisory and nonprivileged data transfers are supported.

The VMIVME-2170A's typical output configuration is shown in Figure 1. The internal configuration of the VMIVME-2170A board is shown in Figure 2.

**Board Function:** 32-bit, optically isolated, digital output board, designed and optimized specifically for the VMEbus. Featuring high isolation, the VMIVME-2170A board is shown in Figure 2.

**Compatibility:** The VMIVME-2170A is a standard double height VME printed circuit board and is electrically and mechanically compatible with the VMEbus.

**Addressing Scheme:** Addressable as four 8-bit ports or two 16-bit registers, located on any 32-bit boundary within the short supervisory or short nonprivileged I/O space.

**Board Address:** The board address is selected by 14 on-board DIP switches. Operation is supported in any available slot in the VMEbus backplane, except slot 1.

**VMEbus Access:** Address modifier bits are decoded to support either short supervisory or nonprivileged short I/O access. A single jumper is provided to support this option and is factory configured for short supervisory I/O access.

**Data Transfer Type:** D16, D8(E0)

**Access Time:** 250 ns maximum

## Output Characteristics

**Output Current Modes:** See Figure 1 and Table 1 for high and low current options.

### Output Configurations:

Current sinking, with pull-up resistor  
 Current sinking, no pull-up resistor  
 Voltage sourcing (low current mode)

### Output Leakage Current:

High Current Version: 500  $\mu$ A maximum at  $V_{CE} = 50$  V and  $T_A = 70$  C

Low Current Version: 50 nA maximum at  $V_{CE} = 10$  V and  $T_A = 70$  C

**Output Voltage:** 30 V maximum

**Switching Time:** See Table 1

**Output Isolation:** 10 M $\Omega$ , minimum

**Isolation Voltage:** 1,000 V maximum sustained field-to-VMEbus, 6,000 V for one second. Sustained channel-to-channel potential is 500 V maximum.

## Physical/Environmental Specifications

**Dimensions:** Double height Eurocard

Height	9.2 in. (233.4mm)
Depth	6.3 in. (160mm)
Thickness	0.8 in. (20.3mm)

### Power Requirements:

1.5 A (typical) at +5 VDC  
 2.2 A (maximum)

**Airflow:** Forced air convection, 400 CFM

### Temperature:

Operating: 0 to +55° C  
 Storage: -20 to +85° C

### Altitude:

Operating: 0 – 10,000 ft (3,000m)

### Humidity:

Operating: relative humidity 20% to 80%, noncondensing

**MTBF:** 153,100 hours (stress)

**Output Connector:** Front panel 64-pin DIN connector. Refer to the Connector Data table on the Ordering Options sheet.

## Related Products and Applications

GE Fanuc Embedded Systems offers a broad range of digital I/O products for VME systems and supports these products with comprehensive applications information. Contact GE Fanuc Embedded Systems for a description of current products and a list of application guides.

## Specifying Factory Options

To accommodate the variety of control output requirements encountered in VMEbus applications, the following VMIVME-2170A characteristics can be specified as factory options:

Data polarity	Positive or negative true
Pull-up resistor sockets	User may select and install pull-up resistors
Output current	2.5 or 300 mA sink

Refer to the Ordering Options to obtain the part number codes associated with each option.

Output current is specified either as *zero* for low (2.5 mA) current, or as *one* for high (300 mA) current. All low current outputs are mutually isolated from each other and from the VMEbus. High current outputs are isolated in groups of four outputs.

The user chooses the pull-up resistor. DIP sockets are installed on the board for these resistor networks. The type of resistor DIPs used must be the isolated type. This DIP has individual resistors between pins across the package. For example, a resistor is between Pins 1 and 16. The value of this resistor is a function of the voltage across it and the power it can dissipate. For example, a 1/8 W DIP with an external voltage ( $V_{ext}$ ) of 48 V would have a value of 18 k $\Omega$  ( $R = V^2/P$ ) as a minimum.

## Trademarks

GE Fanuc Embedded Systems logo is a registered trademark of GE Fanuc Embedded Systems. Other registered trademarks are the property of their respective owners.

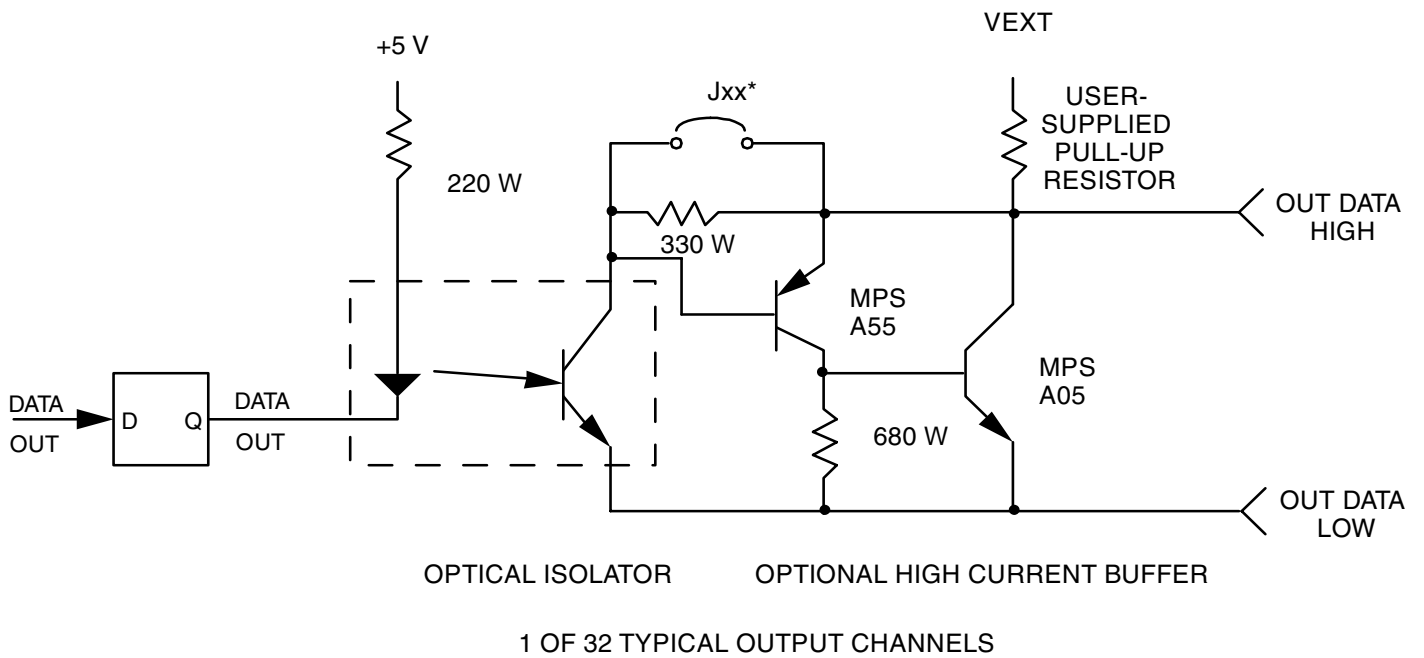

\* Install only Jxx for low current option.  
 Install the resistors and transistors for high current option.  
 Figure 1. VMIVME-2170A Typical Output Configuration

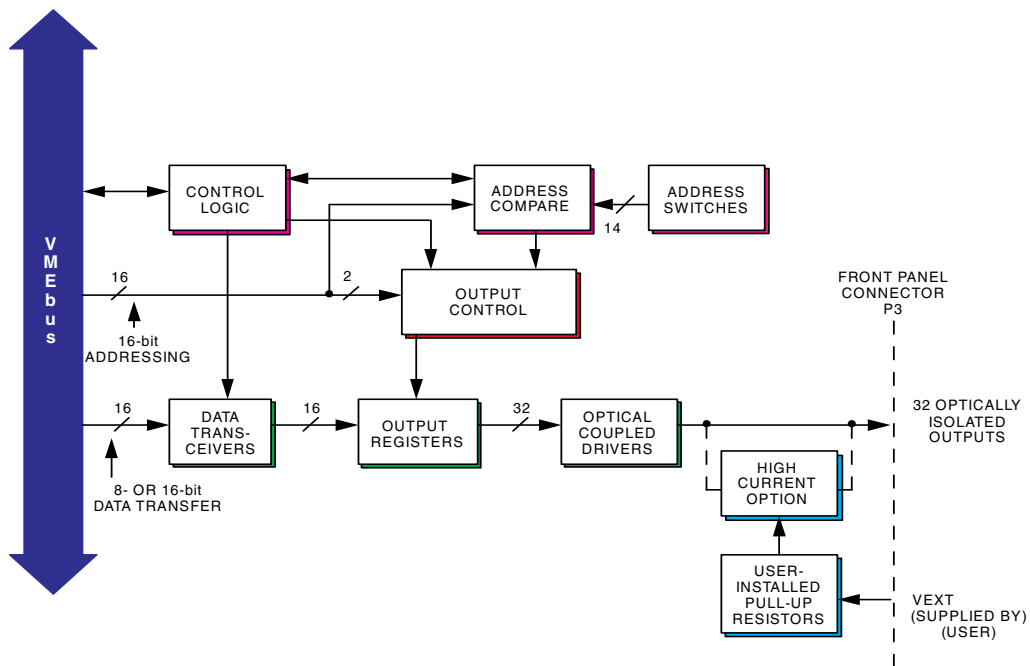

Figure 2. VMIVME-2170A Functional Block Diagram

Table 1. Output Characteristics

<b>HIGH CURRENT OPTION</b>					
<b>Parameter</b>	<b>Conditions</b>	<b>Minimum</b>	<b>Typical</b>	<b>Maximum</b>	<b>Units</b>
$V_{CE}$		50			V
$V_{CE(SAT)}$	$I_{CE} = 300 \text{ mA}$			2.5	V
$I_{CE}$				300	mA
$T_D \text{ ON}$			7.0		$\mu\text{s}$
$T_D \text{ OFF}$			3.5		$\mu\text{s}$
$I_{CEO}$	$V_{CE} = 50 \text{ V } T_A = 70 \text{ C}$			500	$\mu\text{A}$
<b>LOW CURRENT OPTION</b>					
<b>Parameter</b>	<b>Conditions</b>	<b>Minimum</b>	<b>Typical</b>	<b>Maximum</b>	<b>Units</b>
$V_{CE}$		30			V
$V_{CE(SAT)}$	$I_{CE} = 2.5 \text{ mA}$			0.7	V
$I_{CE}$				2.5	mA
$T_D \text{ ON}$			6.0		$\mu\text{s}$
$T_D \text{ OFF}$			25	50	$\mu\text{s}$
$I_{CEO}$	$V_{CE} = 10 \text{ V } I^F = 0$			50	nA



Embedded Systems

GE Fanuc Embedded Systems Information Centers

Americas:  
 Huntsville, AL 1 800 322-3616  
 1 (256) 880-0444  
 Camarillo, CA 1 (805) 987-9300  
 Greenville, SC 1 (864) 627-8800  
 Richardson, TX 1 (972) 671-1972

Europe, Middle East and Africa:  
 Edinburgh, UK 44 (131) 561-3520  
 Paris, France 33 (1) 4324 6007

Additional Resources

For more information, please visit the  
 GE Fanuc Embedded Systems web site at:  
[www.gefanuc.com/embedded](http://www.gefanuc.com/embedded)